

# Scarifier User manual

## PS 700-25

cod. 112731



Please read the instructions carefully before starting the machine.



 **GREENBAY**



AGRIEURO s.r.l.  
Fraz. Petrognano, 50/D - 06049 - Spoleto - PG- Italy



REV20250521



## PRODUCT LISTS



1



2



3



4

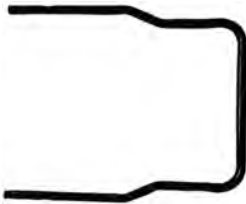

5



6



2x

7



4x

8



Assembly



2-3

Starting-up the machine



4-8

Cutting instructions



9

Operation



10

Cleaning / Maintenance



11-15

2

1

# Assembly

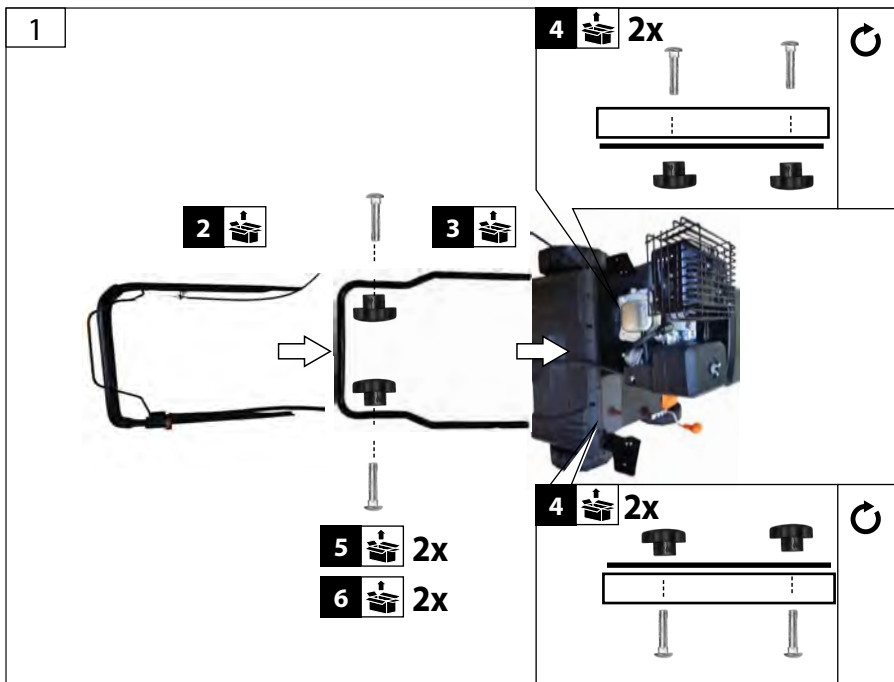

# Assembly



3



2

## Assembled



4

## Cutting height setting

2

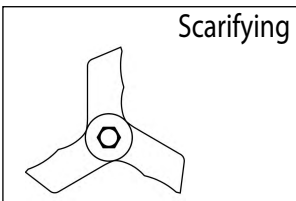
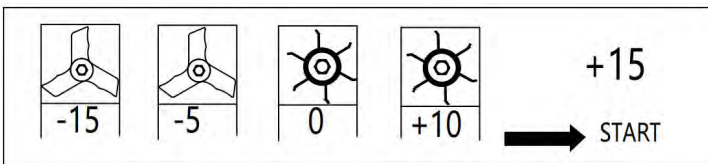
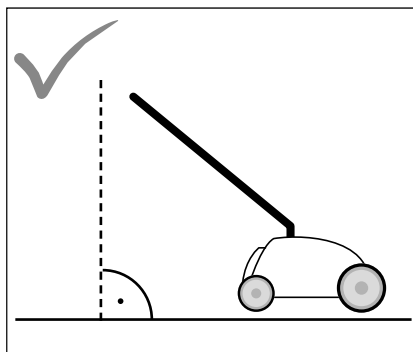

Scarifying

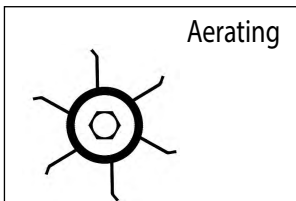

Aerating

# Oil level inspection



**10W-40**

Check the oil level whenever the appliance is to be put into operation. Add engine oil if necessary.

Check the oil level whenever the appliance is to be put into operation. Add engine oil if necessary.

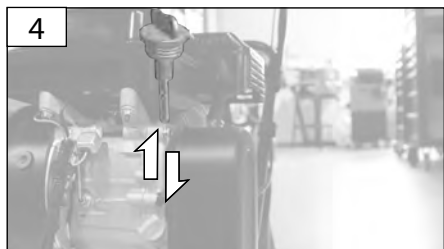
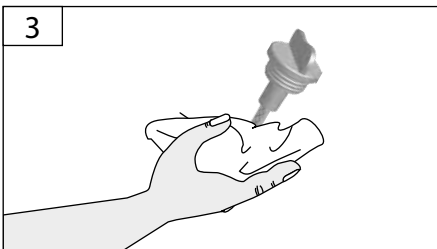
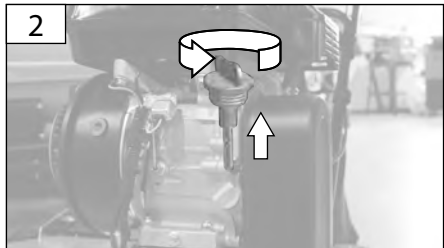
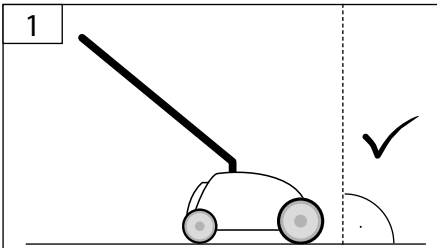

6



## Oil level inspection



5

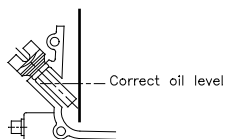

**10W40**  
max 0,6 l

6

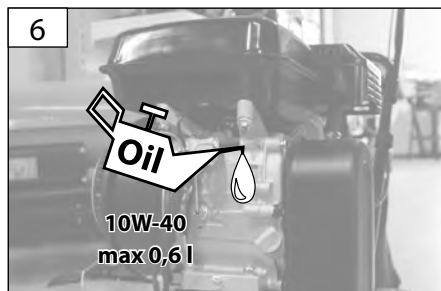

7

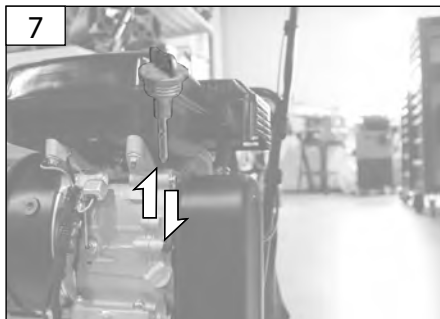

8

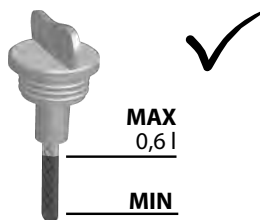

## Oil level inspection



7



To ensure quality, every piece of equipment is subject to a test operation and filled with motor oil. Oil is drained before transport; however, there can be some motor oil remains on the dip stick. Please check carefully the oil level and add motor oil again. 5 - 6

## Fuel tank filling

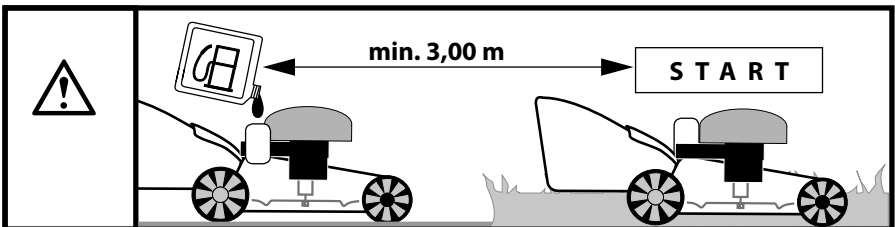
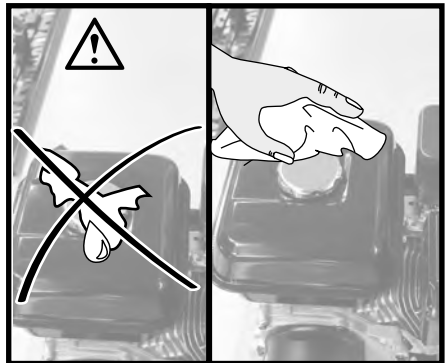
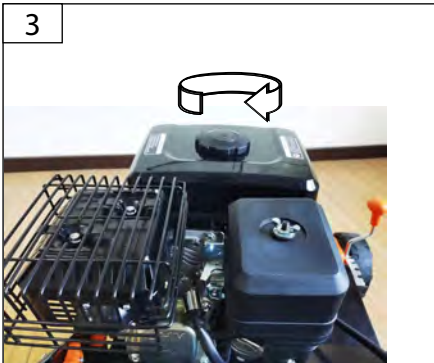
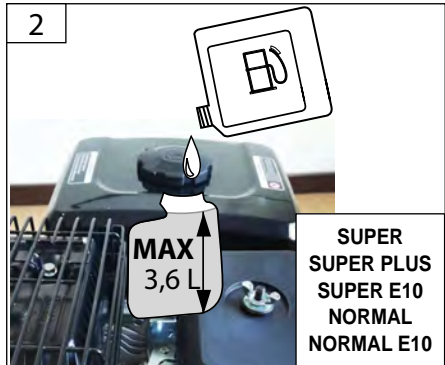
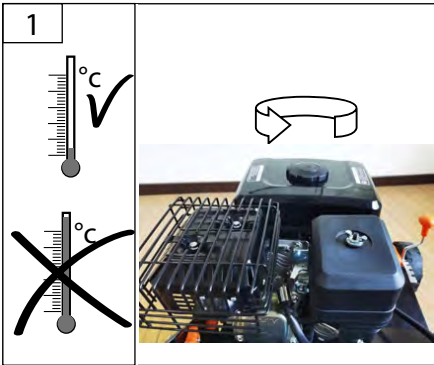

# Cutting instructions

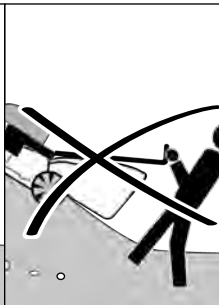
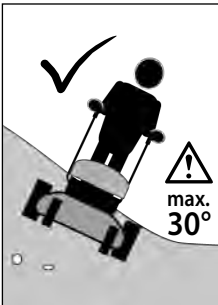
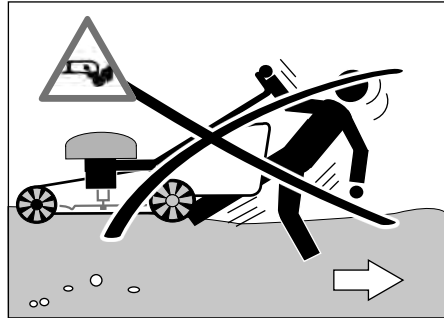
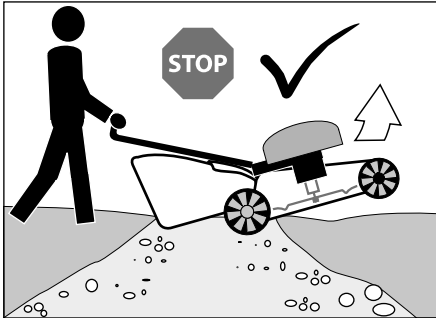
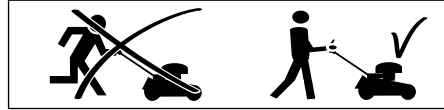
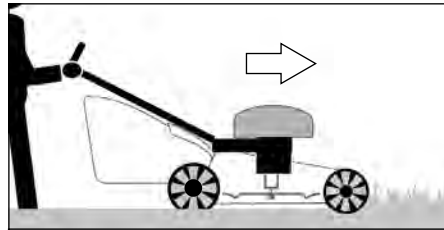
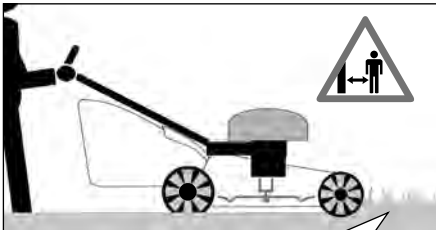

# START 4 STOP

## Operation

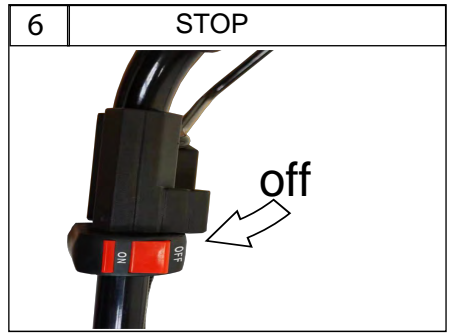
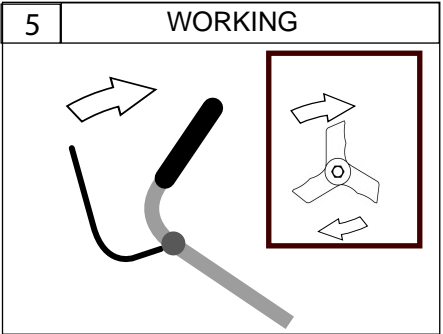
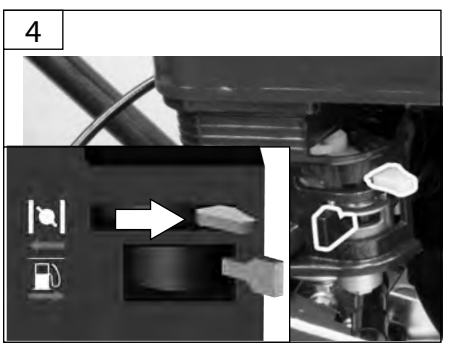
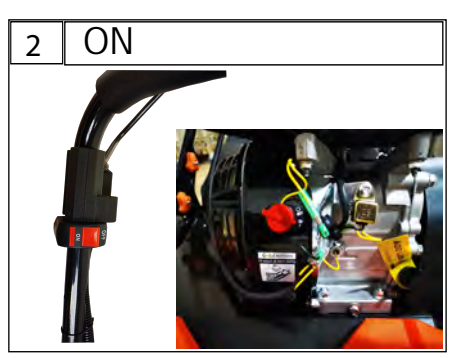

# Cleaning / Maintenance

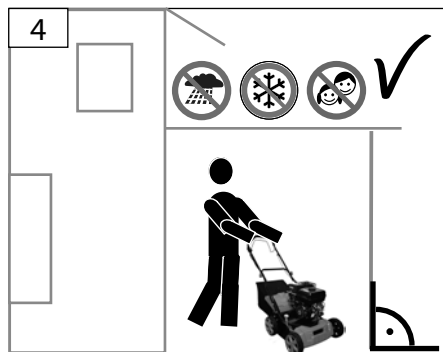
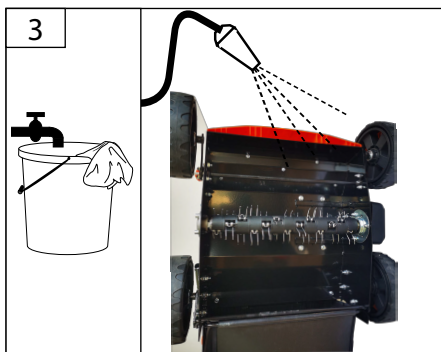
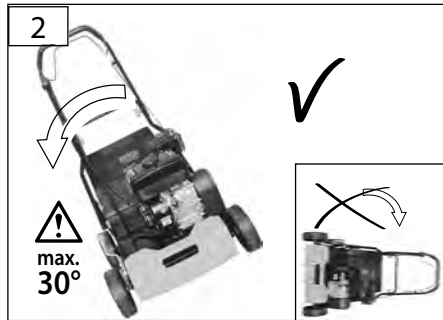
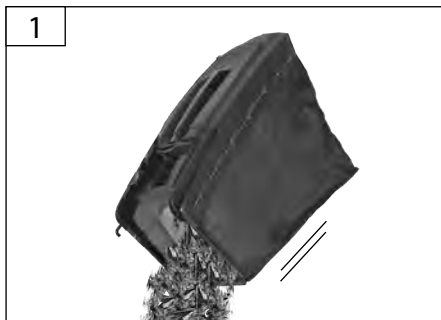
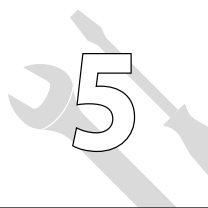

# Cleaning / Maintenance

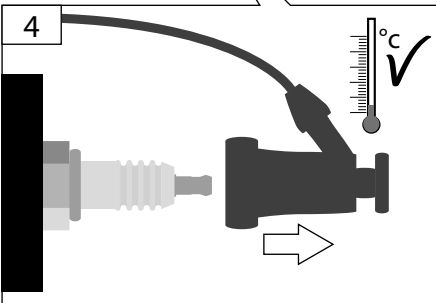
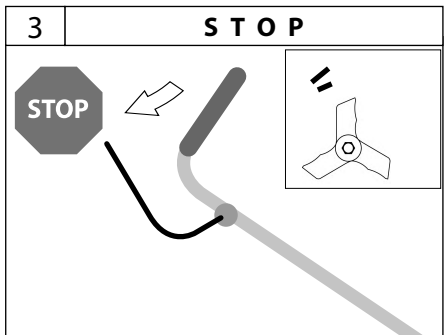
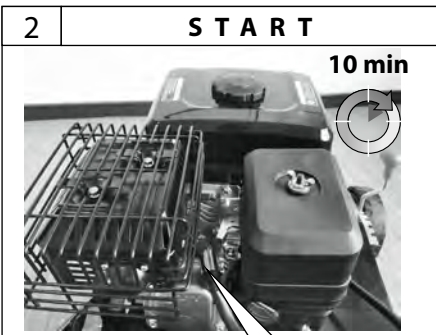
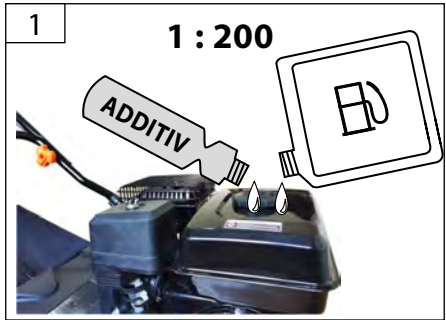
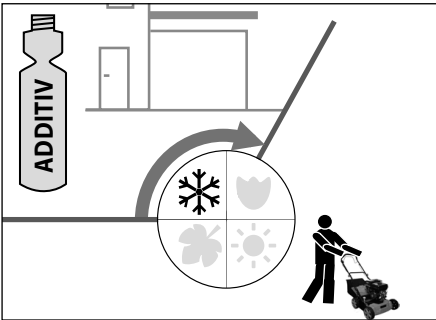
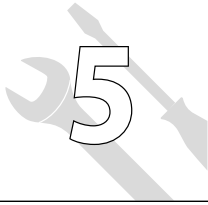

# Spark plug



13

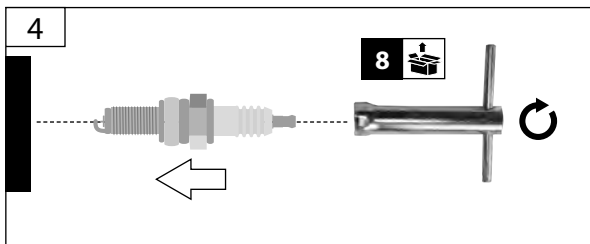
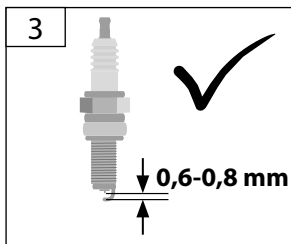
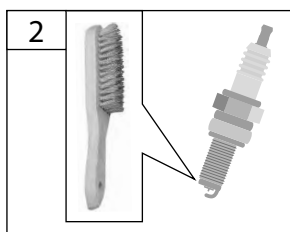
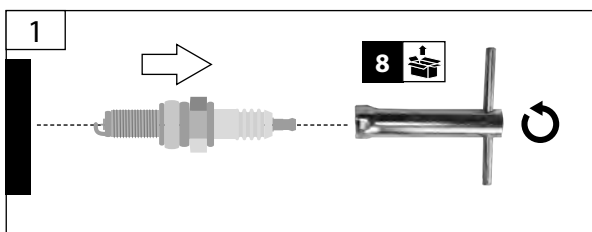
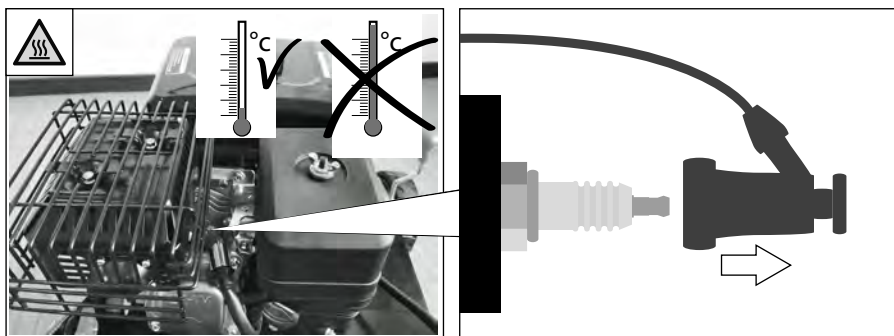

# Oil change



6

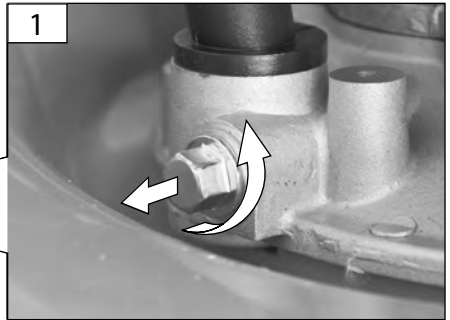
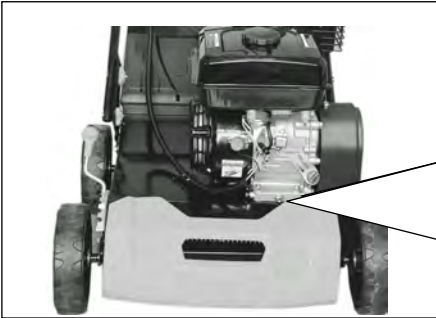

# Air filter

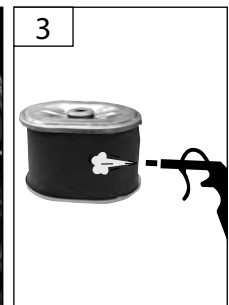
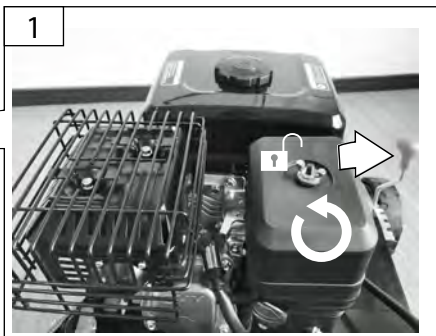



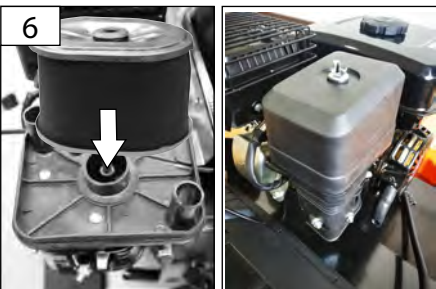
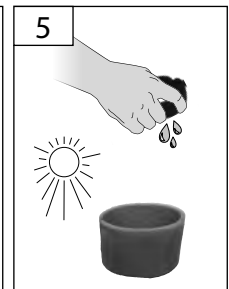
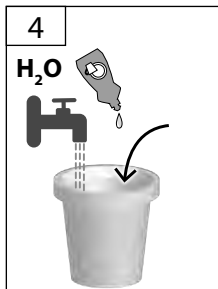





Paper filter to be cleaned with compressed air only!  
Never use water!



## Technical Data

### Scarifier

Art. No. .... **PS 700-25**

	Contents.....	208cm <sup>3</sup>
	Power,	
	OHV 4-stroke motor.....	4.3 kW (5,8 PS)
	Rated speed.....	3600 min <sup>-1</sup>
	Cutting width.....	400 mm
	Cutting depth.....	
	.....	-15 / -10 / 0 / +10 / +15 mm
	Collection bag capacity.....	50 L
	Fuel tank capacity.....	3,6 L
	Super/ Unleaded petrol/ E10	
	Weight.....	35 kg

### Noise and Vibration Information

	Sound pressure level L <sub>PA</sub> <sup>1)A)</sup> .....	86,5 dB (A)
	Sound power level L <sub>WA</sub> <sup>1)B)</sup> .....	103 dB (A)

### Wear ear protectors!

Vibration emission value ----- 4.34 m/s<sup>2</sup>  
K=1,5 m/s<sup>2</sup>

Measured according to <sup>1)</sup> EN 836 <sup>2)</sup> 2000/14/EC

**WARNING:** The vibration emission level will vary because of the ways in which a power tool can be used and may increase above the level given in this information sheet.

The vibration emission level may be used to compare one tool with another.

It may be used for a preliminary assessment of exposure.

An accurate estimate of the vibratory load should also take into account the times when the tool is shut down or when it is running but not actually in use.

This may significantly reduce the vibratory load over the total working period.

Identify additional safety measures to protect the operator from the effects of vibration such as: maintain the tool and the accessories, keep the hands warm, organisation of work patterns.



Read and understand the operating instructions before using the appliance. Familiarise with the

control elements and how to use the appliance properly. Abide by all the safety measures stated in the service manual. Act responsibly toward third parties.

The operator is responsible for accidents or risks to third parties.

In case of any doubts about connection and operation refer please to our customer center

## Information on noise reduction

A certain level of noise from this device is unavoidable. Carry out very noisy work during the permitted

and specified times. Comply with any statutory rest periods and restrict the duration of work to what is necessary. For the protection of yourself and those around you, suitable hearing protection must be worn.

## Specified Conditions Of Use

The scarifier is designed for scarifying and aerating small to medium lawn areas at homes and allotments.

The scarifier must not be used for any other purposes as it may present a risk of physical injury to the user and others.

Do not use this product in any other way as stated for normal use. Not observing general regulations in force and instructions from this manual does not make the manufacturer liable for damages.

 Use the appliance only outside, never use it in confined and bad ventilated areas.

 The scarifier must not be used to trim bushes, hedges and shrubs, for cutting and shredding creepers or lawns on greened roofs or in balcony boxes. In addition, the scarifier must not be used as a shredder for shredding tree and hedge cuttings or for levelling uneven surfaces.

## Requirements for operating staff

Never let children work with the appliance. Never let adults work with the appliance unless they have been properly trained.

The operating staff must carefully read the Operating Instructions before using the appliance.

**Qualification:** Apart from the detailed instructions by a professional, no special qualification is necessary for appliance using.

**Minimum age:** Persons over 16 years of age can only work on the appliance. An exception includes youngsters trained in order to reach knowledge under supervision of the trainer during occupational education.

Local regulations may stipulate the minimum age of the user.

**Training:** Using the appliance only requires corresponding training by a professional or the Operating Instructions. No special training is necessary.

## Residual risks

**⚠ Rotating blades may lead to serious injuries by cutting or amputating parts of the body.**

Never touch under the housing body when the engine is running. Wear protective shoes. Never remove the collection bag when the machine is being operated.

**⚠ Thrown-off stones or soil may lead to injuries.**

Before mowing, check the area to be mowed for any undesirable objects. Make sure the collection bag is properly suspended. Wear safety goggles when working.

**⚠ Poor lighting/light conditions represent a high safety risk.**

Provide adequate lighting or good lighting conditions when working with the machine.

## Emergency procedure

**⚠ Danger of injury !**

Never put your hands and feet near the rotating parts. Keep a distance from the ejection opening at all times.

**⚠ Danger of burns !**

Some parts of the appliance get too hot when the appliance is operated. Do not touch any hot parts, e.g. engine and muffler.

Conduct a first-aid procedure adequate to the injury and summon qualified medical attendance as quickly as possible. Protect the injured person from further harm and calm them down. For the sake of eventual accident, in accordance with DIN 13164, a workplace has to be fitted with a first-aid kit. It is essential to replace any used material in the first-aid kit immediately after it has been used. If you seek help, state the following pieces of information:

1. Accident site
2. Accident type
3. Number of injured persons
4. Injury type(s)

## Symbols



Caution!



Read the Operating Instructions



Wear ear protectors!  
Wear eye protective goggles !



Caution! Blades run down. Wait until all rotating parts have stopped.



Caution - hot surface!  
Danger of burns !



Warning against thrown-off items



Keep distance of persons!  
Observe to keep out of dangerous zone



Switch the engine off and remove the socket plug before any work on the engine.



Keep a sufficient distance from the cutting knife when operating the appliance.



Caution, risk of drawing-in!



Risk of explosion  
Refuel the engine only when switched off.



Risk of poisoning!  
Use the appliance only outside, never use it in confined and bad ventilated areas.



Prohibited smoking and open fire using.



Always keep children and unauthorised persons out of reach of the appliance.



Do not expose the appliance to rain and do not use it in wet or moisture conditions.



Wear safety cut through resistant shoes with safety sole and steel toe !

# AGRIEURO

Fraz. Petrognano, 50/D - 06049 - Spoleto - PG- Italy  
Reg. Imprese di Perugia - C.F. / VAT code 01629170547

## EU DECLARATION OF CONFORMITY

This declaration of conformity is issued under the sole responsibility of the manufacturer:

**AGRIEURO SRL**  
**Fraz. Petrognano 50/D - 06049 Spoleto (PG) – Italy**

Subject matter of the declaration:

<b>PRODUCT</b>	LAWN SCARIFIERS
<b>BRAND</b>	GREENBAY
<b>MODEL(S)</b>	FCP400
<b>CODE(S)</b>	112731
<b>NAME(S)</b>	PS 700-25

The object of the declaration described above is in conformity with the relevant Union harmonisation legislation:

- Directive 2006/42 EC
- Directive 2014/30 EU
- Directive 2000/14 EC, amended by Directive 2005/88 EC

to the following harmonised standards:

- EN 13684:2018
- EN ISO 14982:2009
- EN 3744:1995
- ISO 11094:1991

We also confirm as follows, in accordance with the Emissions Directive 2000/14/EC as amended by Directive 2005/88/EC:

- The measured sound power level on equipment representative of the type subject to this declaration of conformity is: 94 dB(A)
- The guaranteed sound power level for the equipment is: 95 dB (A)

Signed for and on behalf of: ALESSIA SETTIMI

Place SPOLETO

Date 21/05/2025

Signature

**AGRIEURO**<sup>SRL</sup>  
FRAZ. PETROGNANO 50/D - SPOLETO (PG)  
C.F. B P.IVA 01629170547



# MANUALE D'ISTRUZIONI

## Arieggiatore per prato

PS 700-25

cod. 112731



Leggere attentamente il manuale prima di utilizzare la macchina.



 **GREENBAY**



**AGRIEURO s.r.l.**  
Fraz. Petrognano, 50/D - 06049 - Spoleto - PG- Italia

CE



# LISTA DEI PEZZI



1



2



3



4

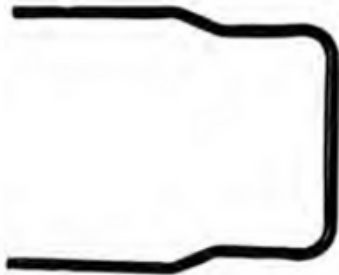

5



6



2x

7



4x

8



Montaggio



2-3

Avviare la macchina



4-8

Istruzioni di taglio



9

Funzionamento



10

Pulizia/manutenzione





11-15







# Montaggio





**1**

**2**  **3** 

**4**  **2x** 

**5**  **2x**  
**6**  **2x**

**4**  **2x** 

Montaggio



3



2

Macchina montata





# Regolazione dell'altezza di taglio

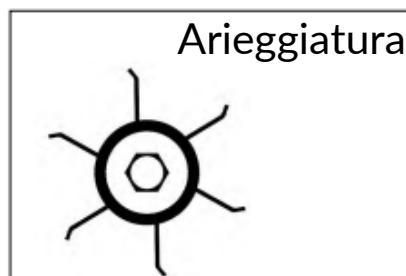
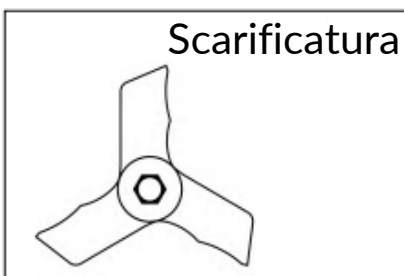
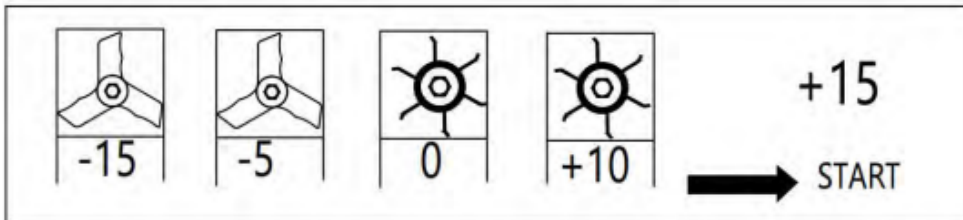
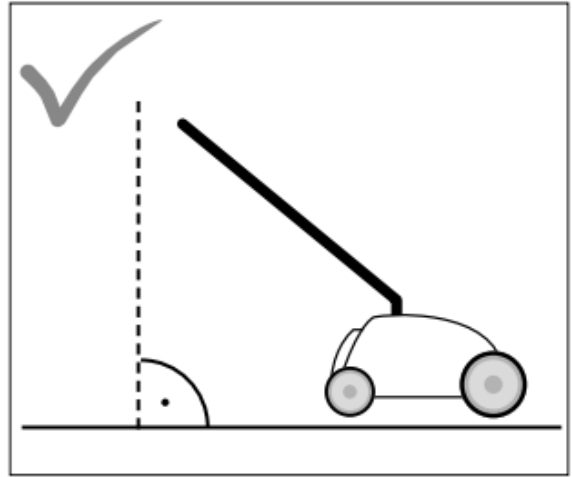

# Controllo del livello dell'olio



**10W-40**

Controllare il livello dell'olio ogni volta che l'apparecchio deve essere messo in funzione. Se necessario, aggiungere olio motore.

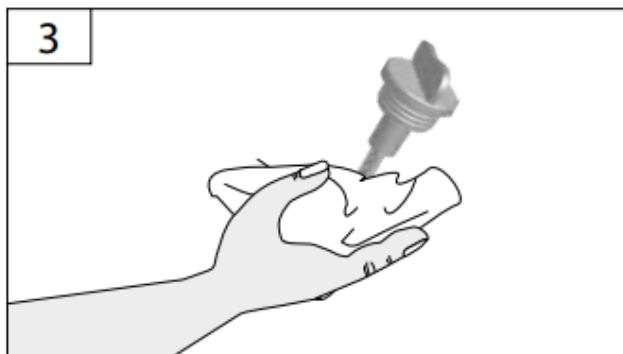
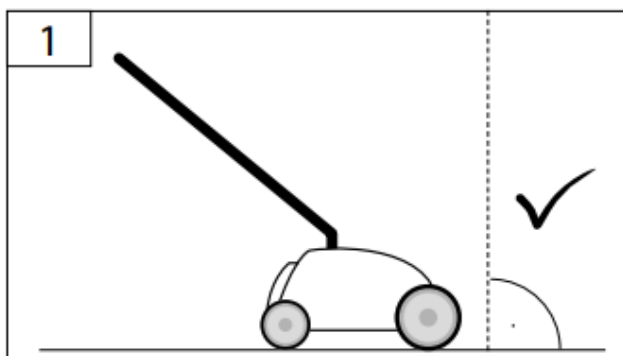



## Controllo del livello dell'olio

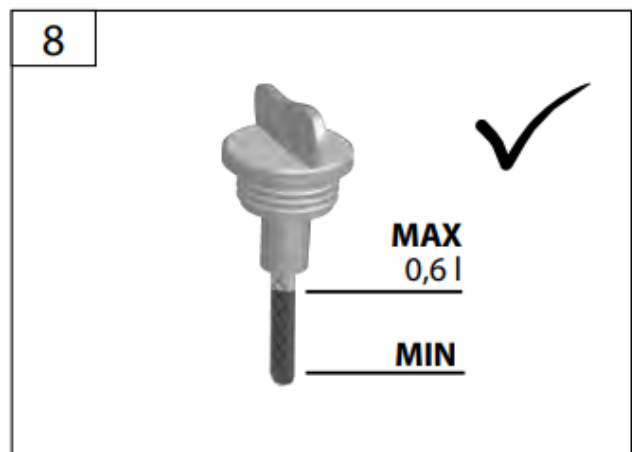
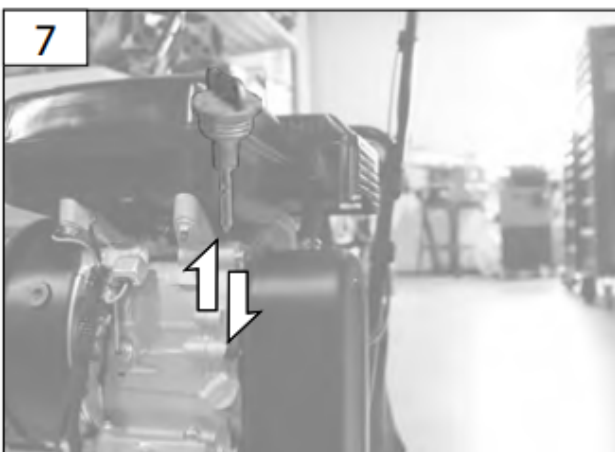
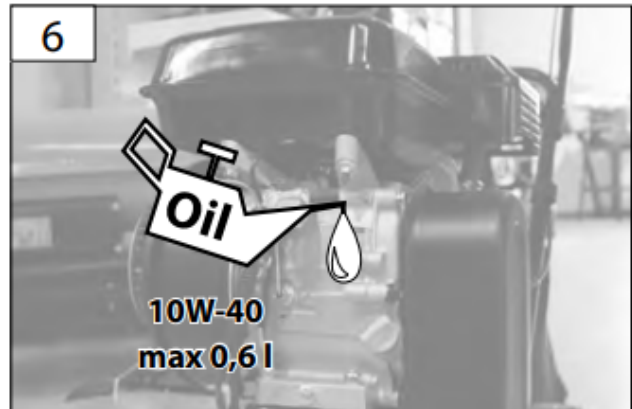
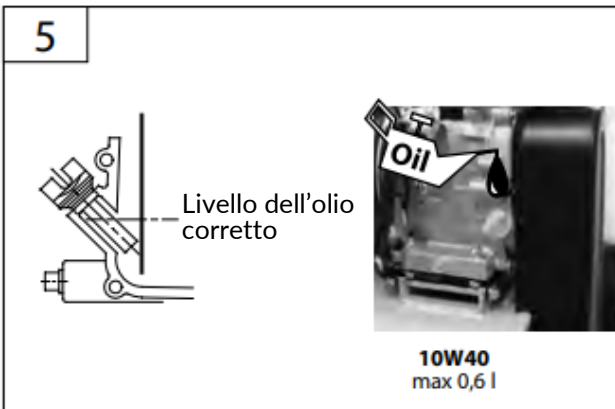

## Controllo del livello dell'olio



7



Per garantirne la qualità, ogni apparecchiatura viene provata e riempita di olio motore.

L'olio viene drenato prima del trasporto; tuttavia, è possibile che sull'asta di livello rimanga dell'olio motore.

Controllare attentamente il livello dell'olio e aggiungere nuovamente olio motore. 5 - 6



## Rifornimento del serbatoio carburante

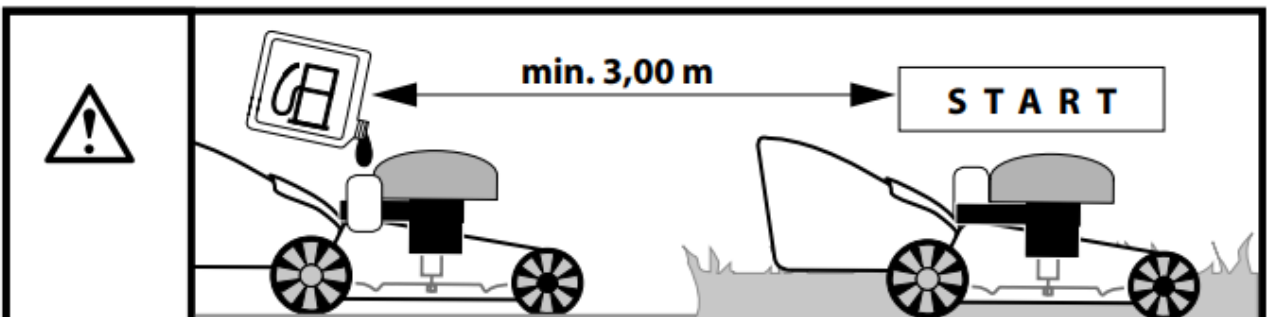
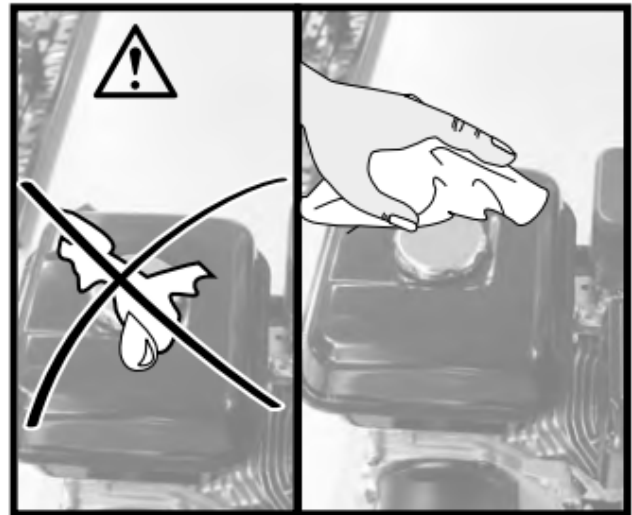
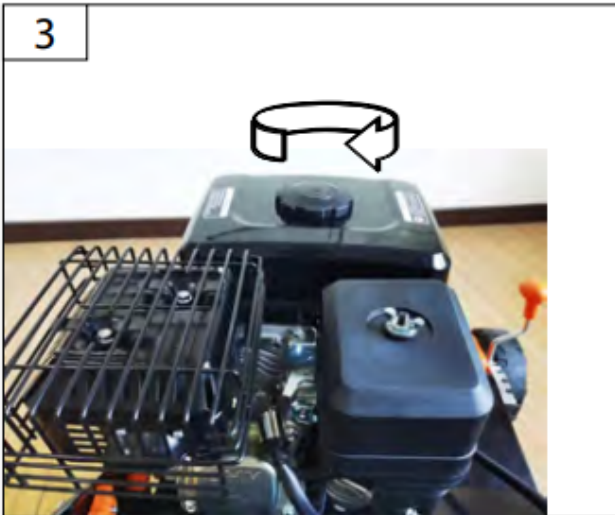
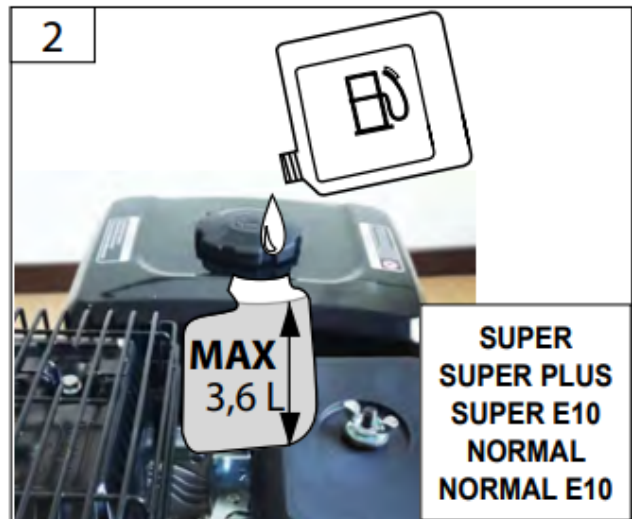
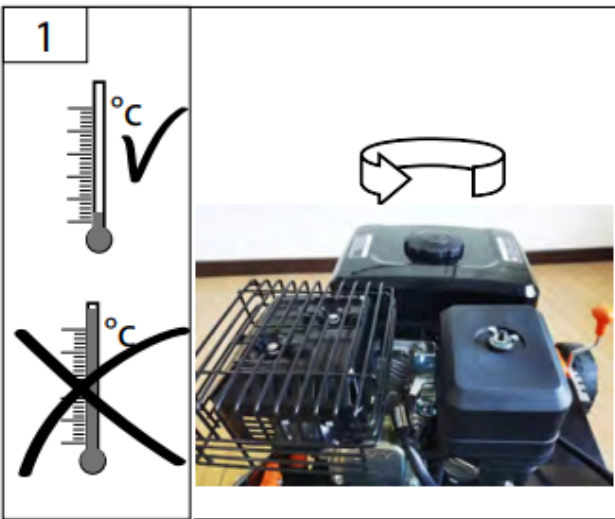

# Istruzioni di taglio

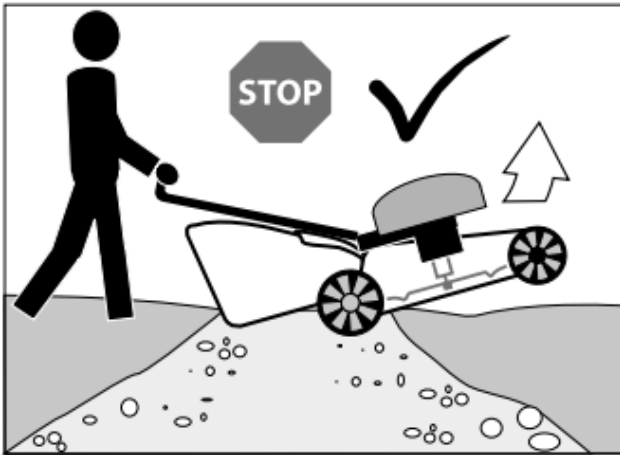
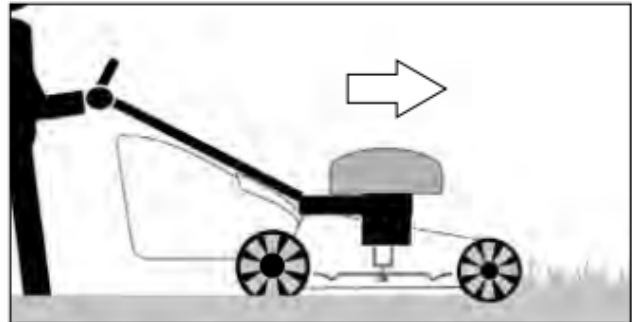
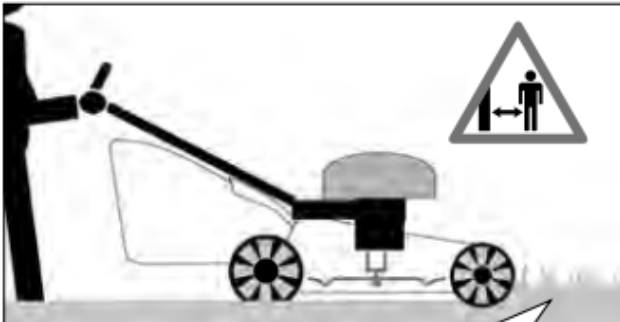

# START 4 STOP

## Funzionamento

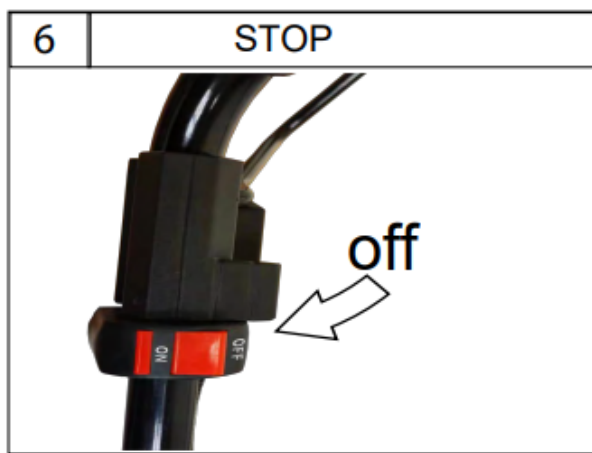
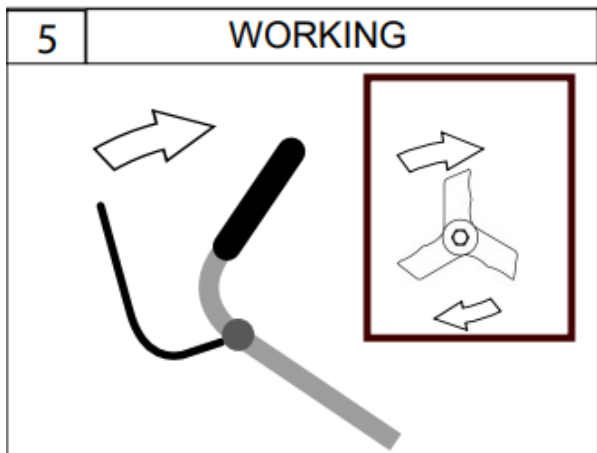
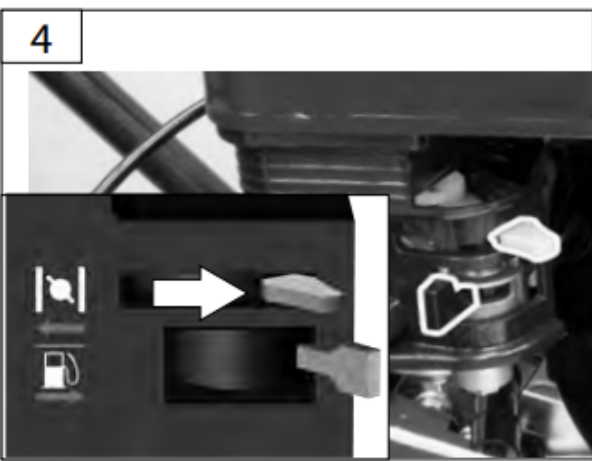
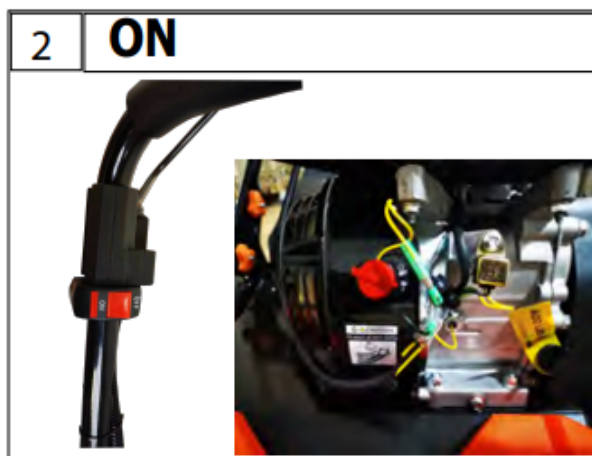
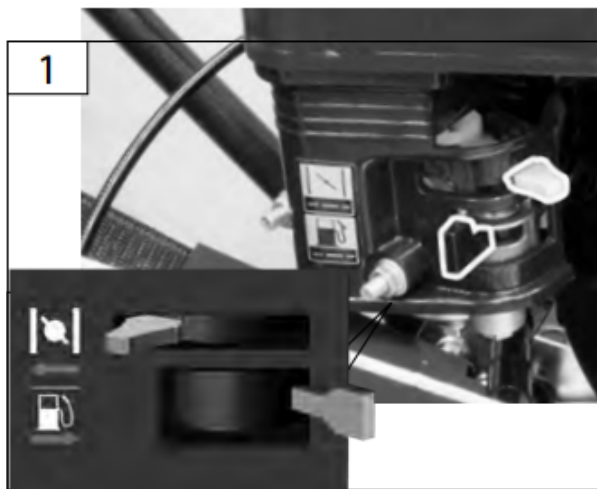

# Pulizia/manutenzione

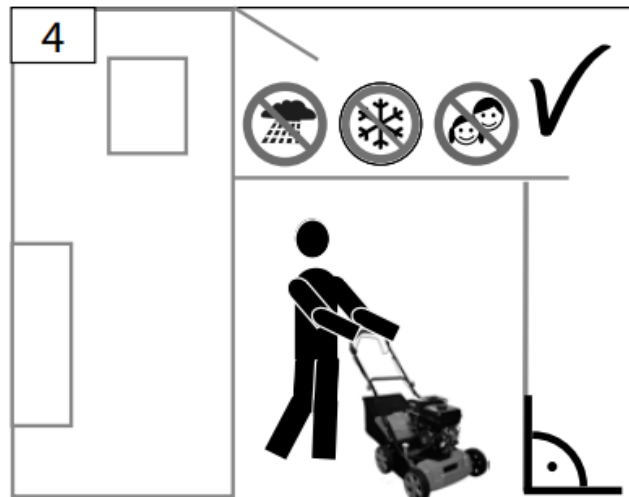
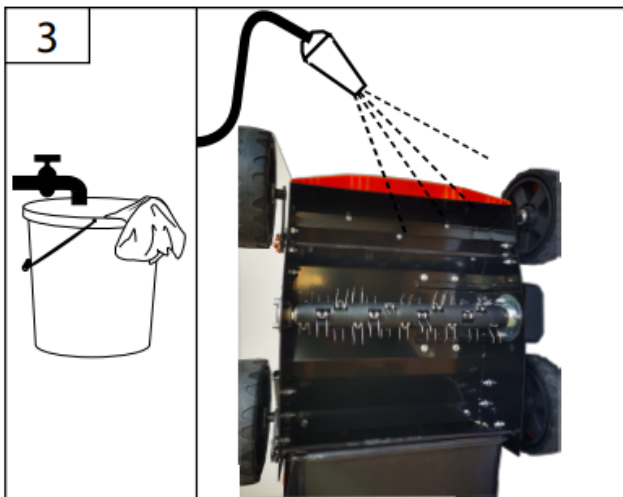
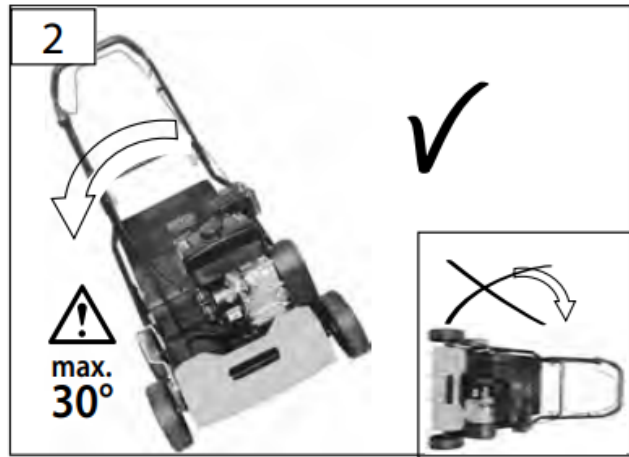



## Pulizia/manutenzione

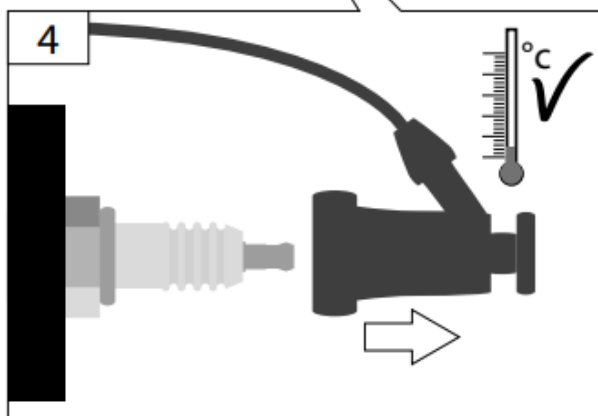
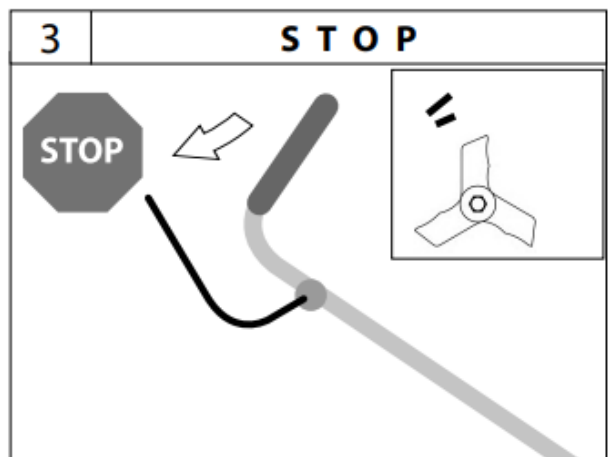
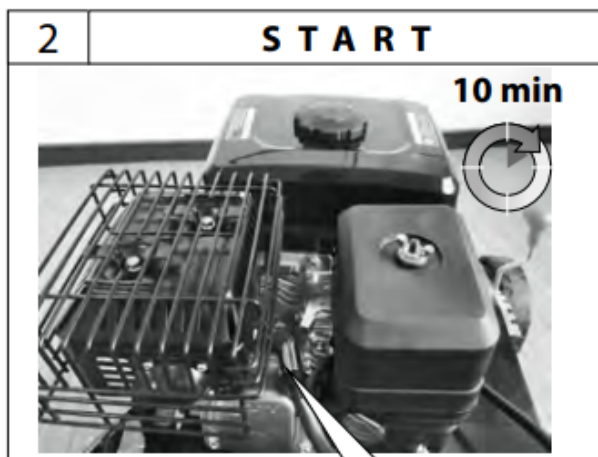
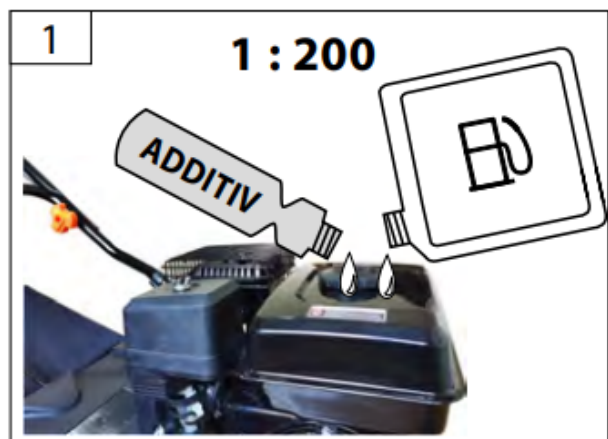
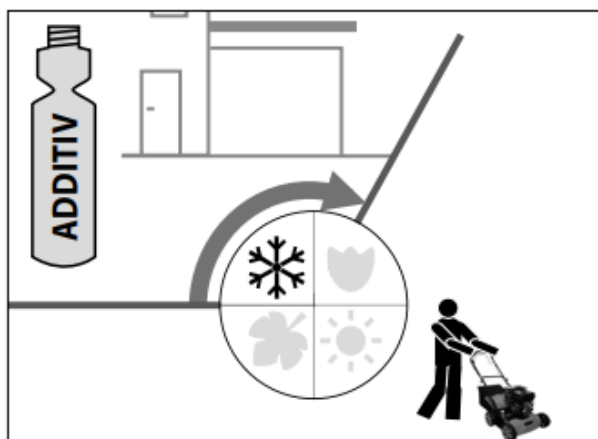

# Candela

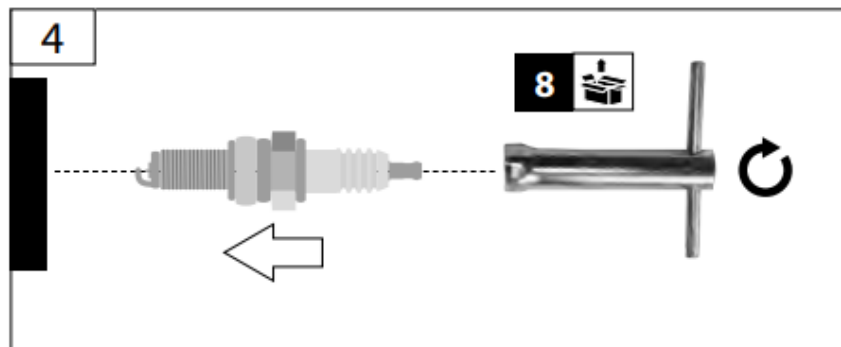
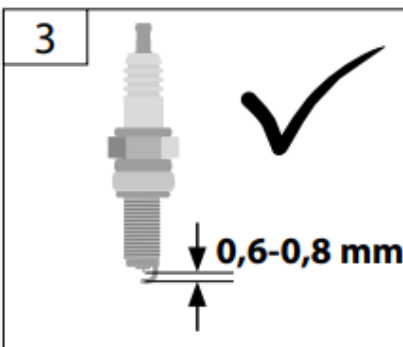
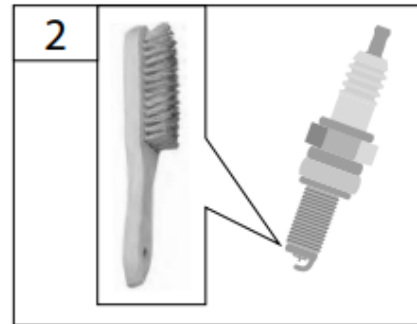
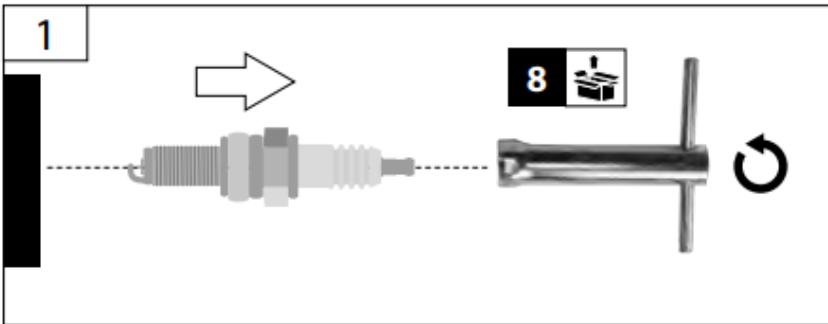
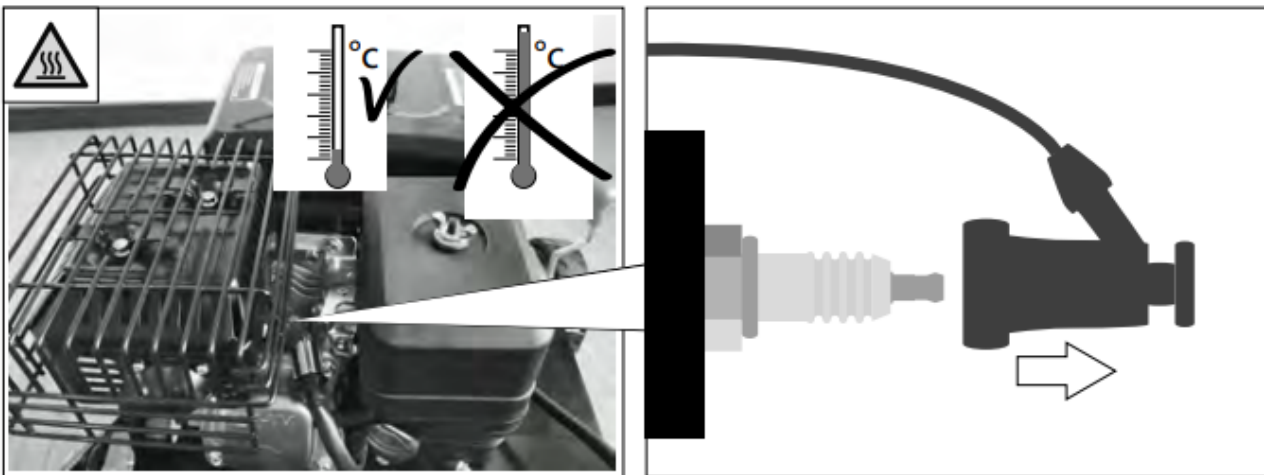



## Sostituzione dell'olio



6

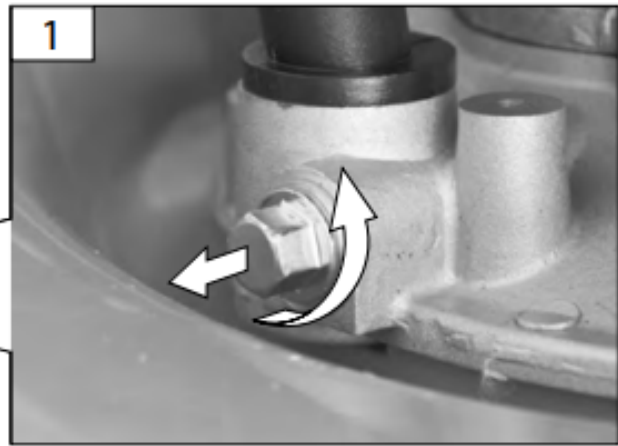
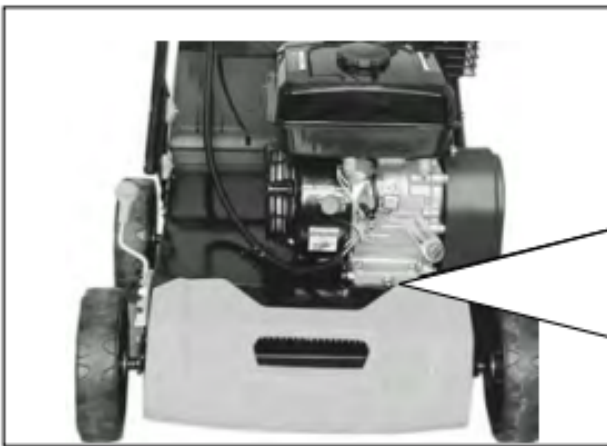

# Filtro dell'aria

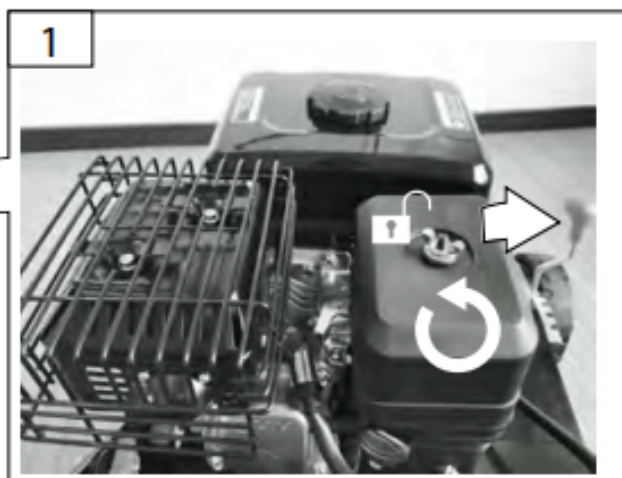



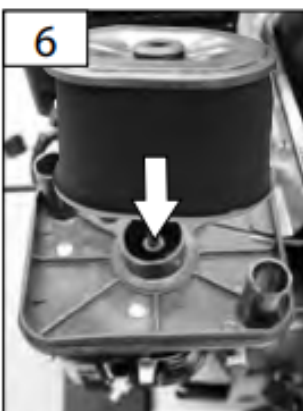
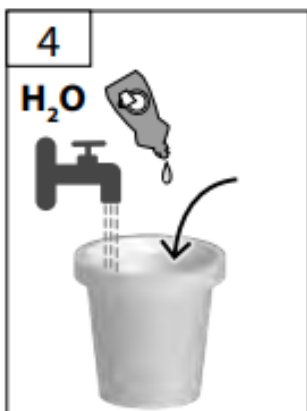





Il filtro di carta deve essere pulito solo con aria compressa!  
Non usare mai acqua.





# Scheda tecnica

## Arieggiatore per prato

Art. No. **PS 700-25**

	Cilindrata.....	208cm <sup>3</sup>
	Potenza motore OHV a 4 tempi .....	4.3 kW (5,8 PS)
	Velocità nominale.....	3600 min <sup>-1</sup>
	Larghezza di taglio .....	400 mm
	Profondità di taglio.....	-15 / -10 / 0 / +10 / +15 mm
	Capienza cesto di raccolta .....	50 L
	Capienza serbatoio.....	3,6 L
	Benzina super/Senza piombo/E10	
	Peso .....	35 kg

### Informazioni su rumore/vibrazione

	Livello di pressione sonora ponderata LpA	86,5 dB (A)
	Livello di potenza sonora LWA.....	103 dB (A)

### Indossare protezione per l'udito!

Valore di emissione di vibrazioni----- 4.34 m/s<sup>2</sup>

K=1,5 m/s<sup>2</sup>

Misurazione conforme a 1) EN 836 2) 2000/14/CE

**AVVERTENZA:** Il livello di emissione delle vibrazioni varia a causa delle modalità di utilizzo della macchina e può aumentare rispetto al livello indicato in questa scheda tecnica.

Il livello di emissione delle vibrazioni può essere utilizzato per confrontare una macchina con un'altra. Può essere utilizzato per una preliminare valutazione dell'esposizione.

Una stima del livello di esposizione alle vibrazioni dovrebbe anche tener conto delle volte in cui lo strumento è spento o quando è in funzione, ma non utilizzato.

Ciò può ridurre in modo significativo il livello di esposizione durante il periodo di lavoro complessivo. Adottare misure di sicurezza supplementari per la protezione dell'operatore dagli effetti delle vibrazioni come ad esempio: effettuare una regolare manutenzione della macchina e degli accessori, tenere al caldo le mani, organizzazione delle modalità di lavoro.



Leggere e comprendere le istruzioni di sicurezza prima di utilizzare la macchina.

Familiarizzare con i componenti di comando e sull'uso corretto dell'apparecchio.

Rispettare tutte le misure di sicurezza indicate nel manuale di manutenzione.

Comportarsi in modo responsabile nei confronti di terzi.

L'operatore è responsabile per incidenti o rischi posti a terzi.

In caso di dubbi sul collegamento e sul funzionamento, rivolgersi al nostro servizio clienti.

### Informazioni sul contenimento del rumore

Un certo livello di rumore generato da questo dispositivo è inevitabile. Eseguire lavori molto rumorosi negli orari consentiti e specificati.

Rispettare i periodi di silenzio previsti dalla legge e limitare la durata del lavoro allo stretto necessario.

Per proteggere sé stessi e chi ci circonda, è necessario indossare un'adeguata protezione dell'udito.

### Condizioni specifiche d'uso

L'arieggiatore è progettato per la scarificazione e l'arieggiatura di aree di prato di piccole e medie dimensioni in abitazioni e lotti.

L'arieggiatore non deve essere utilizzato per altri scopi in quanto può comportare il rischio di lesioni fisiche per l'utente e per gli altri.

Non utilizzare questo prodotto in modo diverso da quello indicato per l'uso ordinario.

L'inosservanza delle norme generali in vigore e delle istruzioni contenute nel presente manuale esclude il produttore da qualsiasi responsabilità per eventuali danni.

 **Utilizzare l'apparecchio solo all'esterno, non utilizzarlo mai in aree ristrette e mal ventilate.**

 **L'arieggiatore non deve essere utilizzato per potare cespugli, siepi e arbusti, per tagliare e sminuzzare rampicanti o prati su tetti invernati o nelle cassette dei balconi. Inoltre, l'arieggiatore non deve essere utilizzato come trituratore per la triturazione di alberi e siepi o per livellare superfici irregolari.**

### Requisiti per il personale operativo

Non permettere mai ai bambini di utilizzare la macchina.

Non lasciare che gli adulti lavorino con la macchina se non sono stati adeguatamente formati.

Prima di utilizzare l'apparecchio, il personale dovrà leggere attentamente le istruzioni per l'uso.

**Qualifiche:** oltre alle istruzioni dettagliate da parte di un esperto, non sono necessarie qualifiche particolari per l'utilizzo dell'apparecchio.

**Età minima:** solo le persone di età superiore ai 16 anni possono utilizzare la macchina. Fanno eccezione i giovani che vengono formati per acquisire conoscenze sotto la supervisione del responsabile della formazione professionale. Le normative locali possono stabilire l'età minima dell'utente.

**Training:** l'utilizzo dell'apparecchio richiede solo una formazione adeguata da parte di un professionista o il manuale d'uso. Non è necessario alcun tipo di formazione specifica.

## Rischi residui

**⚠ Le lame rotanti possono provocare gravi lesioni provocando tagli o amputazioni di parti del corpo.**

Non toccare mai sotto il corpo dell'alloggiamento quando il motore è in funzione. Indossare scarpe antinfortunistiche. Non rimuovere mai il sacco di raccolta quando la macchina è in funzione.

**⚠ Pietre o terriccio possono provocare lesioni se scagliati dalla macchina.**

Assicurarsi che il sacco di raccolta sia correttamente sospeso. Indossare occhiali di sicurezza durante il lavoro.

**⚠ Le condizioni di scarsa illuminazione rappresentano un rischio elevato per la sicurezza.**

Fornire un'illuminazione adeguata o buone condizioni di illuminazione durante le operazioni svolte con la macchina.

## Procedure di emergenza

**⚠ Pericolo di lesioni!**

Non mettere le mani o i piedi vicino o sotto le parti rotanti. Tenersi a debita distanza dall'ingresso dello scarico.

**⚠ Pericolo di ustioni!**

Alcune parti della macchina si surriscaldano durante il funzionamento. Non toccare parti roventi. Ad esempio, motore e marmitta.

Eseguire una procedura di primo soccorso adeguata al tipo di lesione e chiamare al più presto personale medico qualificato. Proteggere la persona ferita da ulteriori danni e tranquillizzarla. Per fronteggiare un eventuale incidente, in conformità alla norma DIN 13164, un luogo di lavoro deve essere dotato di una cassetta di pronto soccorso. È essenziale che il materiale della cassetta di pronto soccorso venga sostituito immediatamente dopo l'uso.

In caso di richiesta di aiuto, indicare le seguenti informazioni:

1. Luogo dell'incidente;
2. Tipologia di incidente;
3. Numero di infortunati;
4. Tipologia di lesione (o lesioni).

## Simboli



Attenzione!



Leggere attentamente le istruzioni



Indossare protezione per l'udito!  
Indossare protezioni per gli occhi!



Attenzione: le lame si abbassano. Attendere che tutte le parti in movimento si siano fermate.



Attenzione - superficie rovente!  
Pericolo di ustioni!



Attenzione agli oggetti scagliati!



Tenere le persone a distanza!  
Osservare le norme di sicurezza per evitare di trovarsi in una zona pericolosa.



Prima di qualsiasi intervento sul motore, spegnerlo e togliere la spina dalla presa.



Mantenere una distanza sufficiente dal coltello da taglio mentre in funzione.



Attenzione, rischio di intrappolamento!



Rischio di esplosione!  
Rifornire il motore solo se spento.



Rischio di avvelenamento!  
Utilizzare la macchina solo all'esterno, non utilizzarla mai in aree ristrette e mal ventilate.



Vietato fumare e utilizzare fiamme libere.



Tenere sempre i bambini e le persone non autorizzate lontano dalla macchina.



Non esporre la macchina alla pioggia e non utilizzarla in condizioni di umidità.



Indossate scarpe antitaglio con suola di sicurezza e punta d'acciaio!

# AGRIEURO

Fraz. Petrognano, 50/D - 06049 - Spoleto - PG- Italy  
Reg. imprese di Perugia - C.F. / P. IVA (VAT code) IT01629170547

## DICHIARAZIONE DI CONFORMITÀ UE

La presente dichiarazione di conformità è rilasciata sotto la responsabilità esclusiva del fabbricante:

**AGRIEURO SRL**  
**Fraz. Petrognano 50/D - 06049 Spoleto (PG) – Italia**

Oggetto della dichiarazione:

<b>PRODOTTO</b>	ARIEGGIATORI PER PRATO
<b>MARCA</b>	GREENBAY
<b>MODELLO/I</b>	FCP400
<b>CODICE/I</b>	112731
<b>NOME/I</b>	PS 700-25

L'oggetto della dichiarazione di cui sopra è conforme alla pertinente normativa di armonizzazione dell'Unione:

- Direttiva 2006/42 CE
- Direttiva 2014/30 UE
- Direttiva 2000/14 CE e sua modifica Direttiva 2005/88 CE

alle seguenti norme armonizzate:

- EN 13684:2018
- EN ISO 14982:2009
- EN 3744:1995
- ISO 11094:1991

Confermiamo inoltre quanto segue, in conformità alla direttiva sulle emissioni 2000/14/CE modificata dalla direttiva 2005/88/CE:

- Il livello di potenza sonora misurato su un'apparecchiatura rappresentativa del tipo oggetto della dichiarazione di conformità è: 94 dB(A).
- Il livello di potenza sonora garantita per l'apparecchiatura è: 96 dB (A).

Firmato a nome e per conto di: ALESSIA SETTIMI

Luogo SPOLETO

Data 21/05/2025

Firma

**AGRIEURO**<sup>SRL</sup>  
FRAZ. PETROGNANO 50/D - SPOLETO (PG)  
C.F. B.P.IVA 01629170547



# MANUEL D'INSTRUCTIONS

## Scarificateur-Aérateur pour le gazon

PS 700-25

code 112731



Lisez attentivement ce manuel avant d'utiliser la machine.



 **GREENBAY**



AGRIEURO s.r.l.  
frazione San Venanzo 11- 06049 - Spoleto - PG- Italie

CE



# LISTE DES COMPOSANTS



1



2



3



4

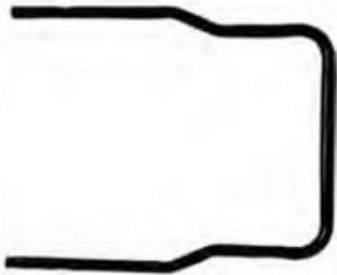

5



6



2x

7



4x

8



Montage



2-3

Démarrer la machine



4-8

Instructions de scarifiage



9

Fonctionnement



10

Nettoyage et entretien



11-15

# Montage



1

2

3

4 2x

5 2x

6 2x

4 2x



## Montage

3



2

## Machine assemblée





# Réglage de la hauteur de travail

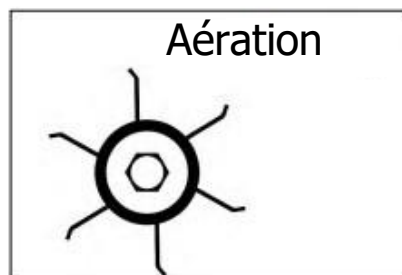
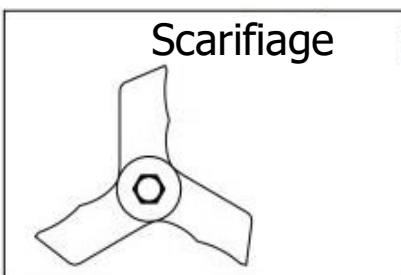
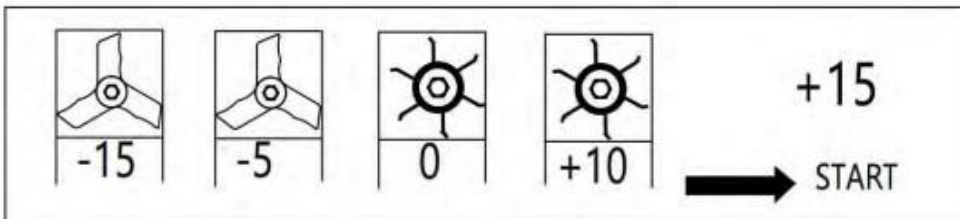
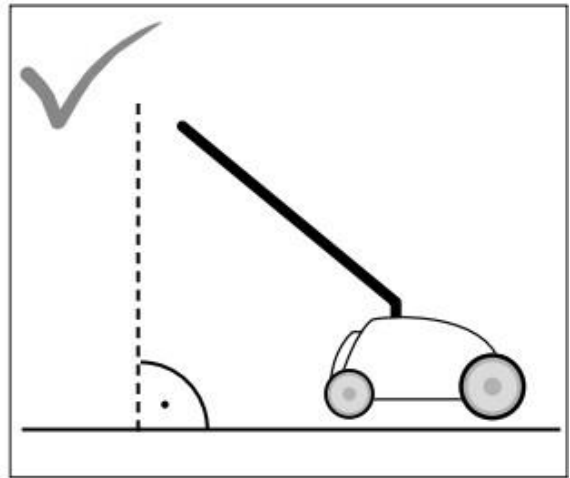

# Vérification du niveau d'huile



**10W-40**

Vérifiez le niveau d'huile chaque fois que la machine doit être mise en service.  
Si nécessaire, faites l'appoint d'huile moteur.

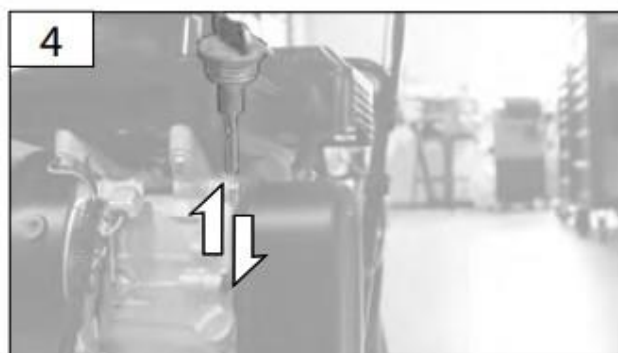
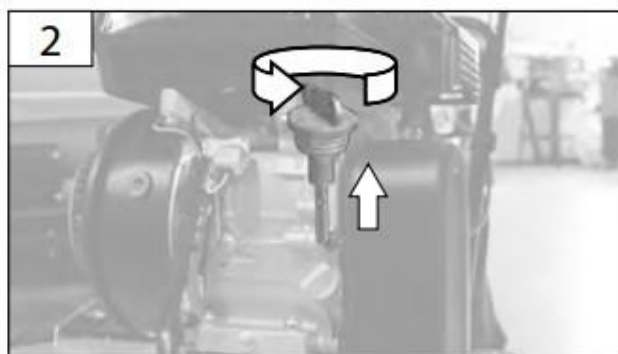
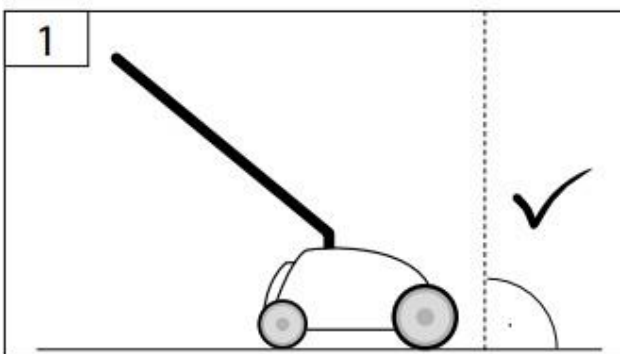



## Vérification du niveau d'huile

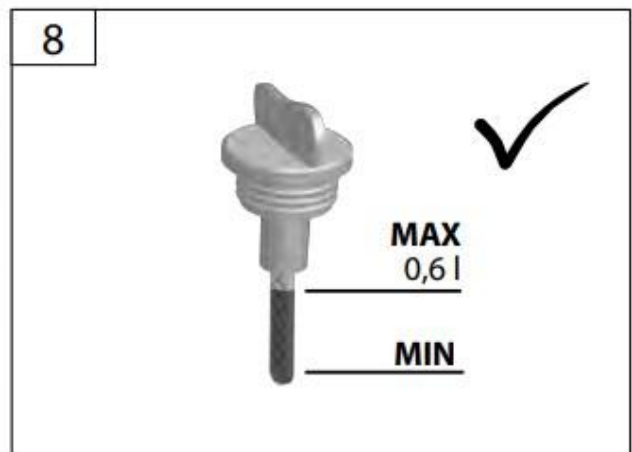
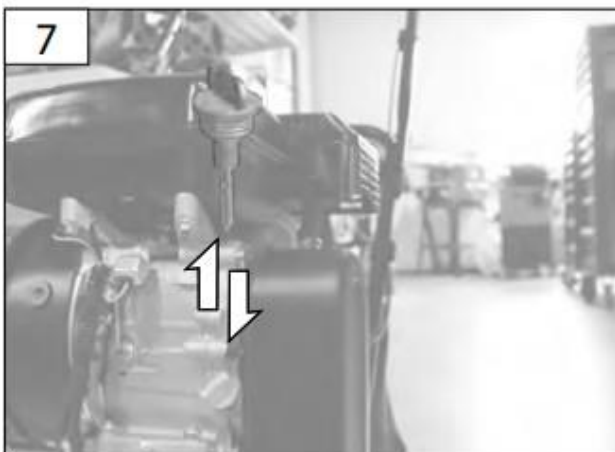
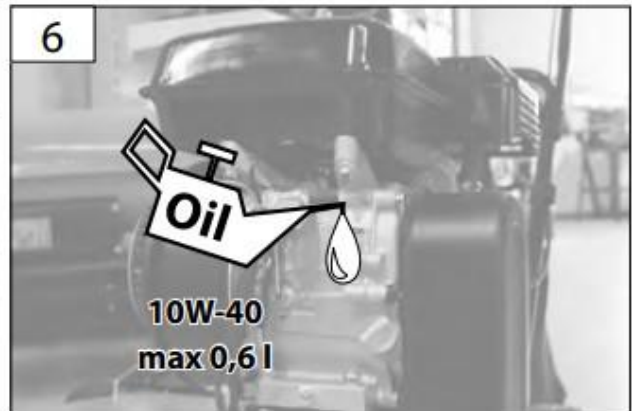
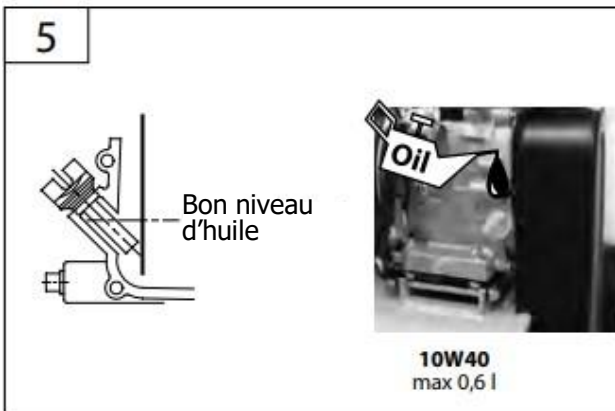

## Vérification du niveau d'huile



7



Check the oil level whenever the appliance is to be put into operation. Add engine oil if necessary.  
Check the oil level whenever the appliance is to be put into operation. Add engine oil if necessary.



## Ravitaillement du réservoir de carburant

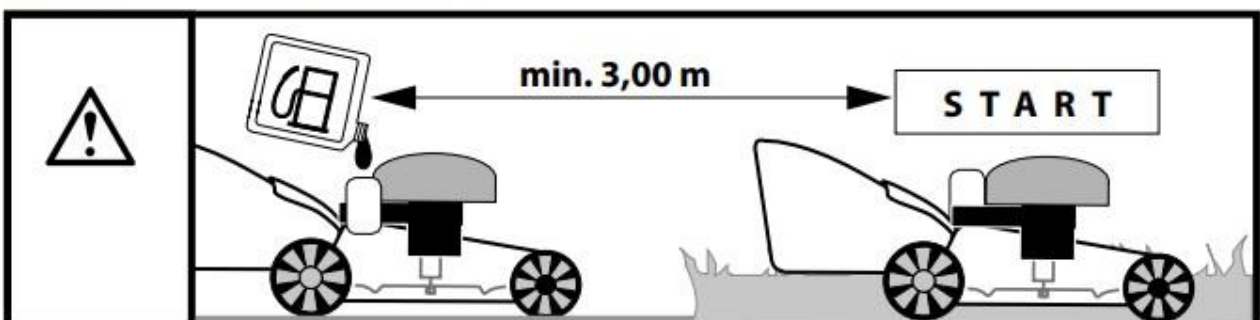
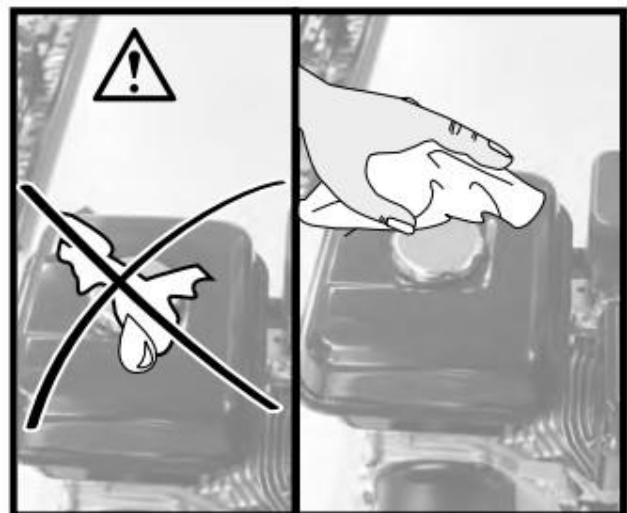
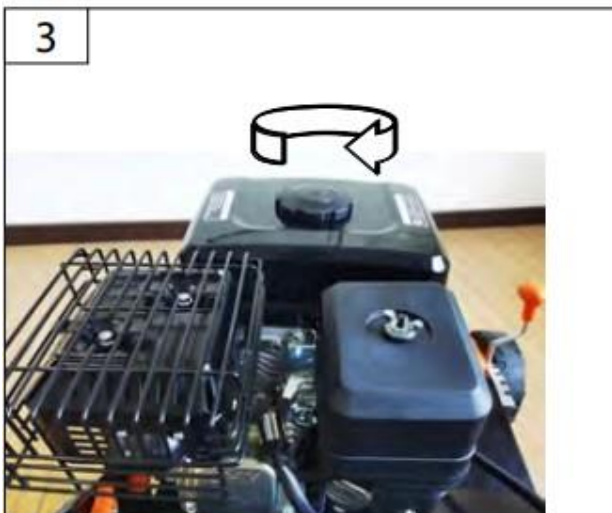
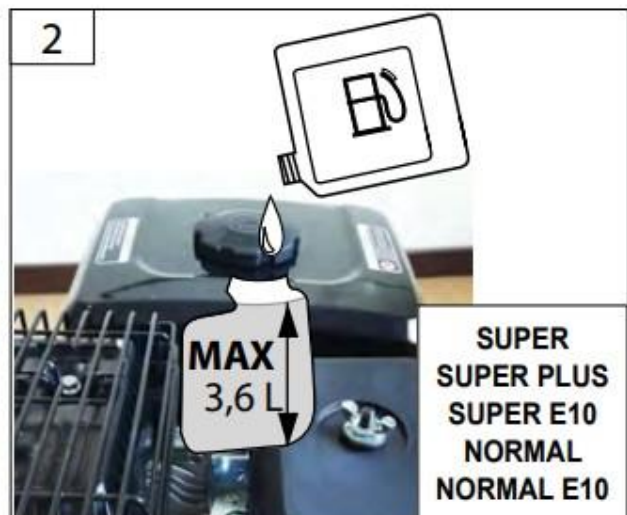
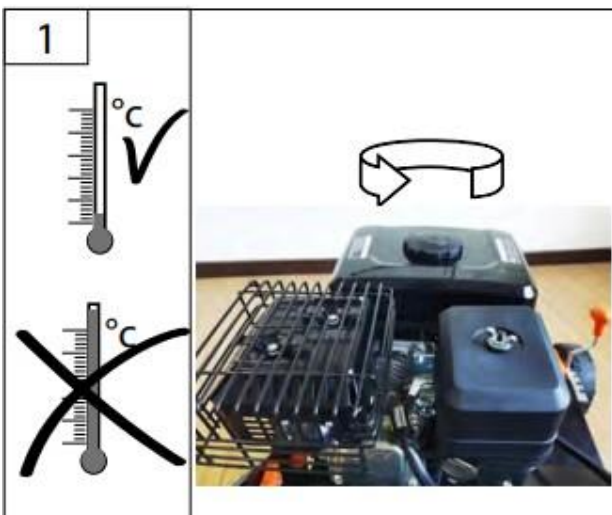

# Instructions de scarifiage

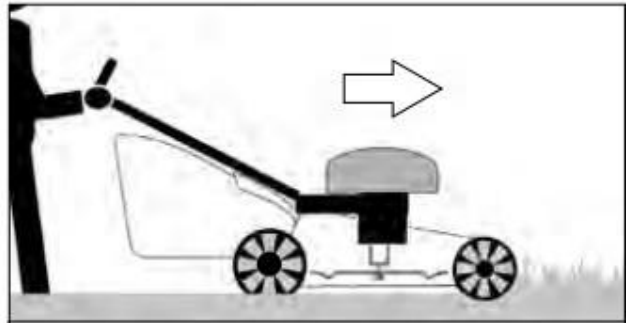
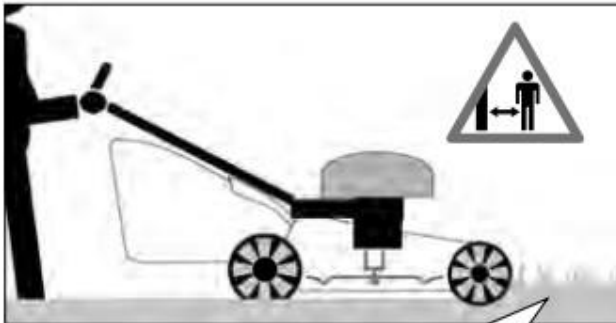

# START 4 STOP

## Fonctionnement

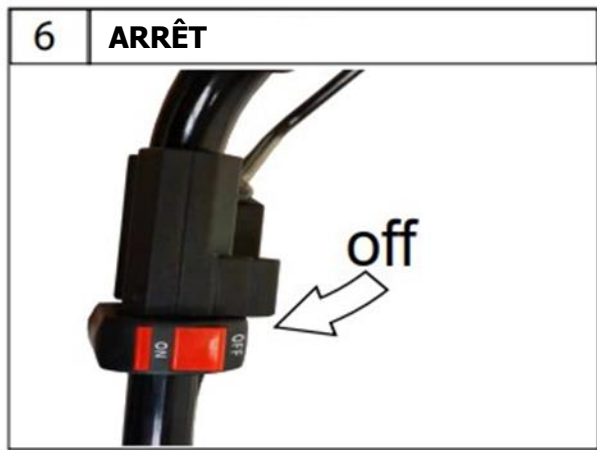
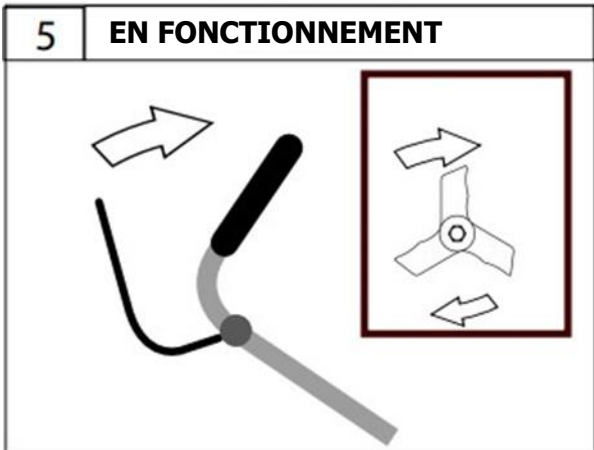
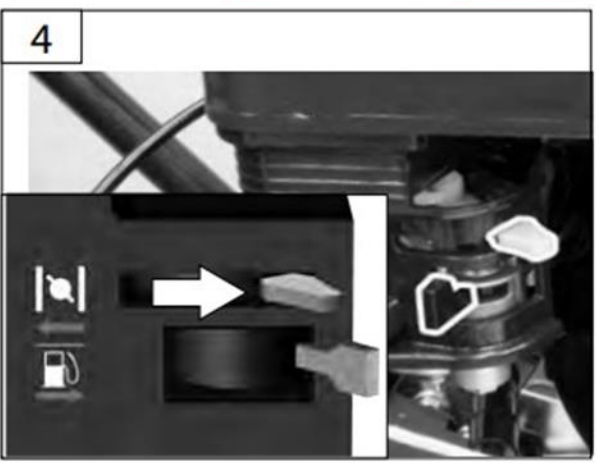
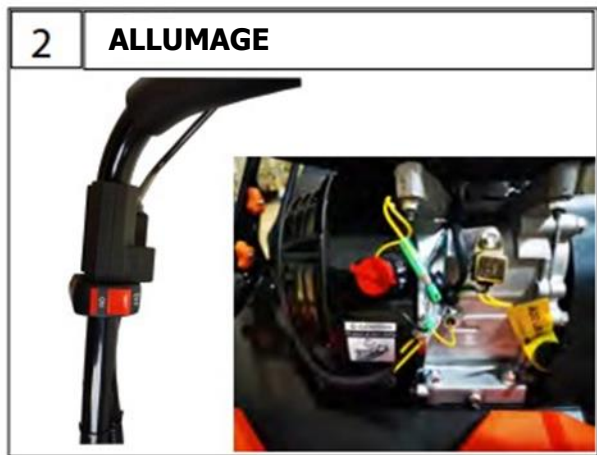

# Nettoyage et entretien

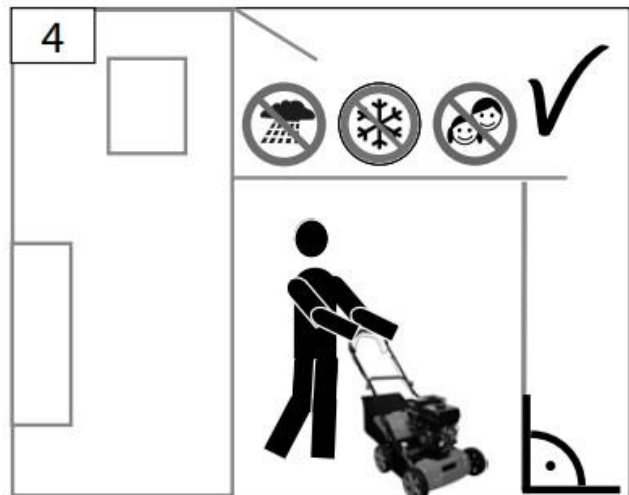
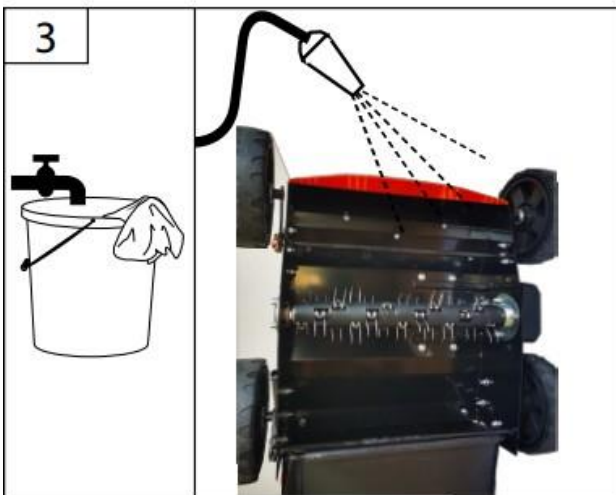
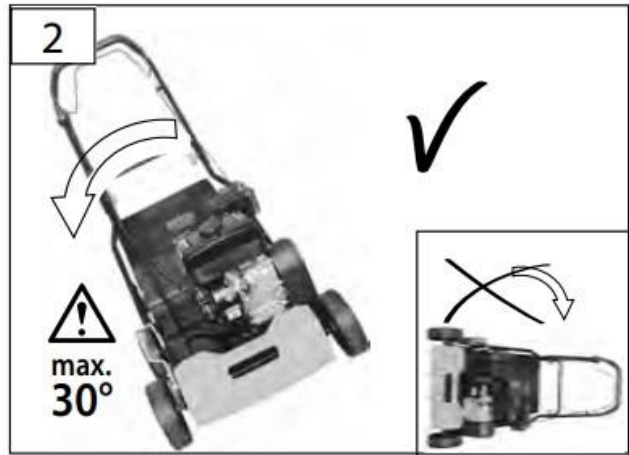

# CleanNettoyage et ice entretien

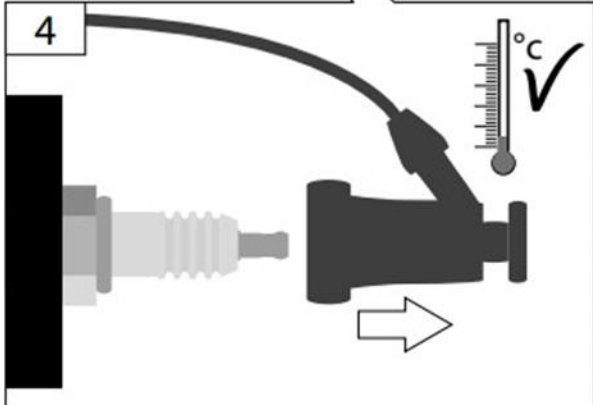
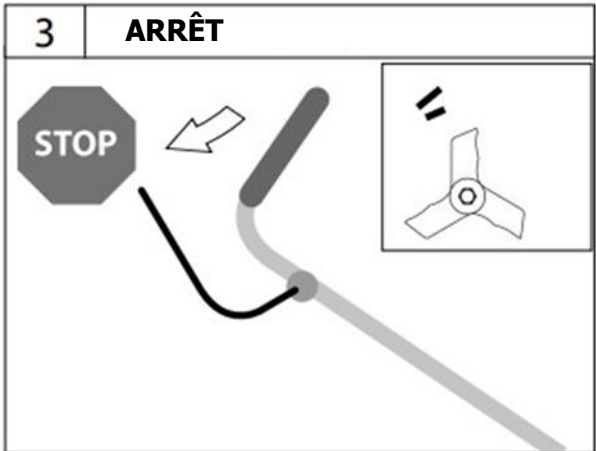
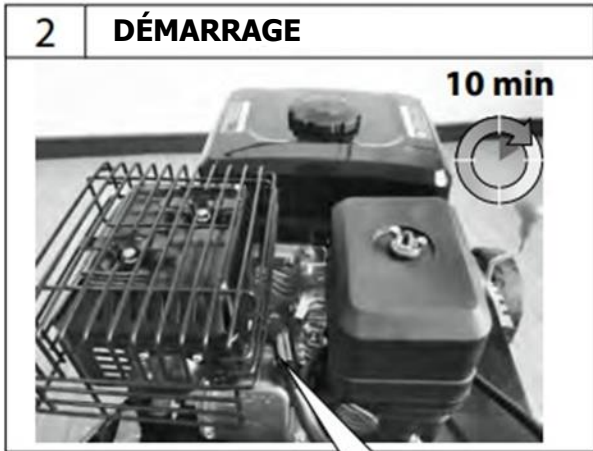
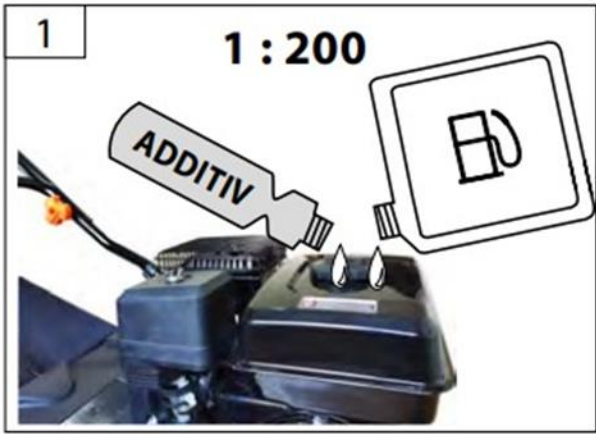
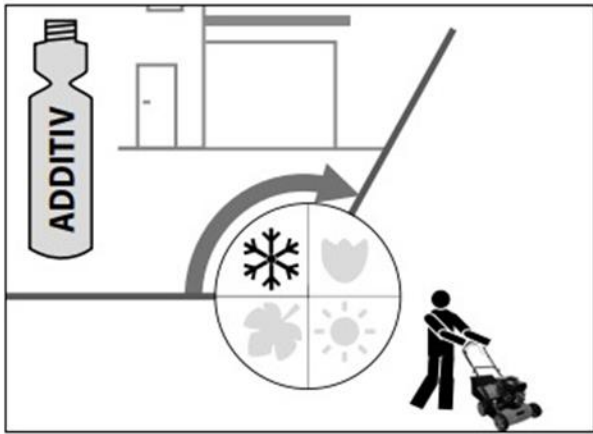

# Bougie

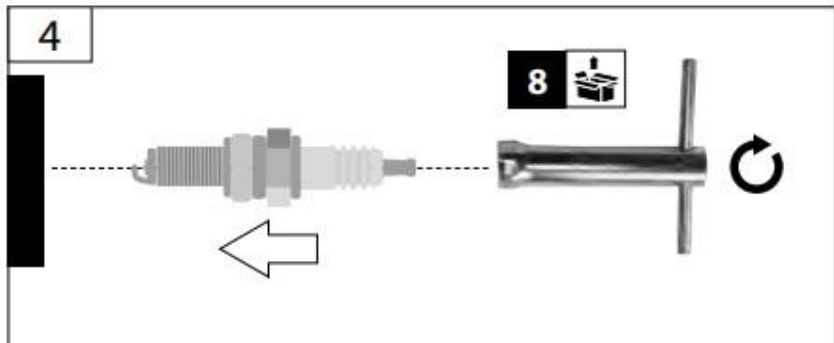
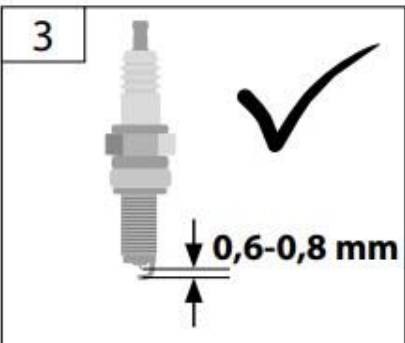
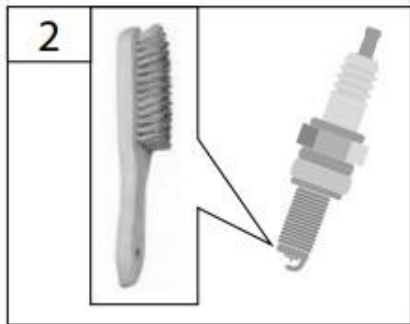
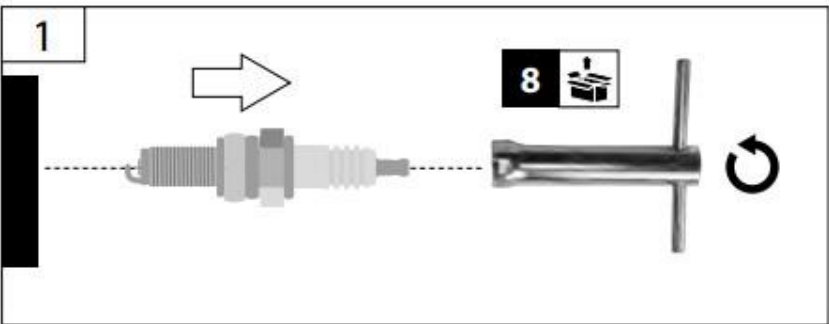
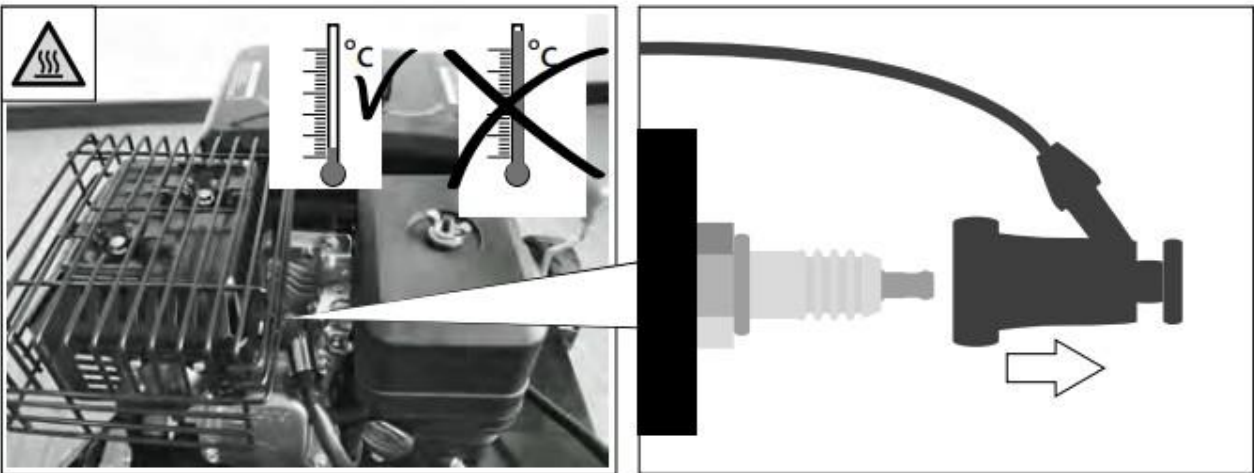

# Vidange de l'huile

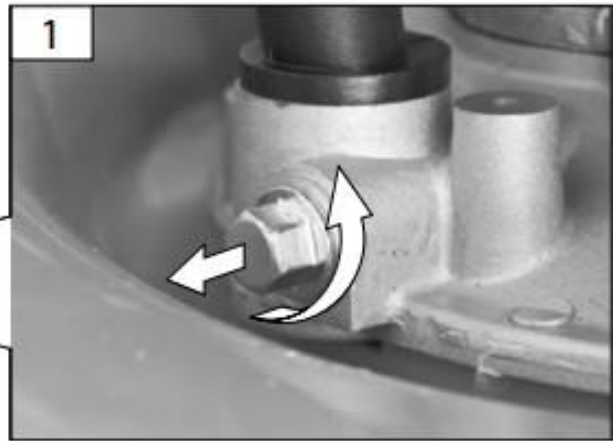
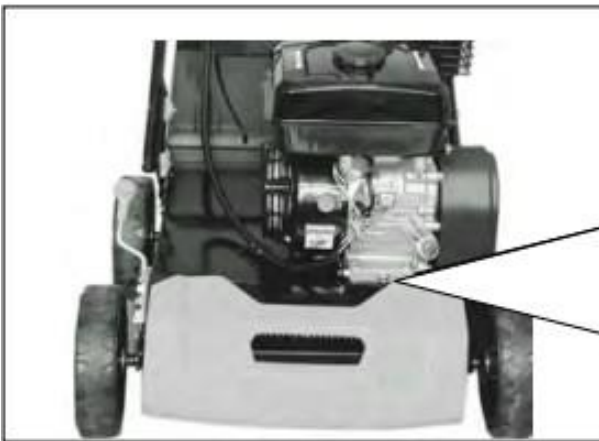
**6**

# Filtre à air

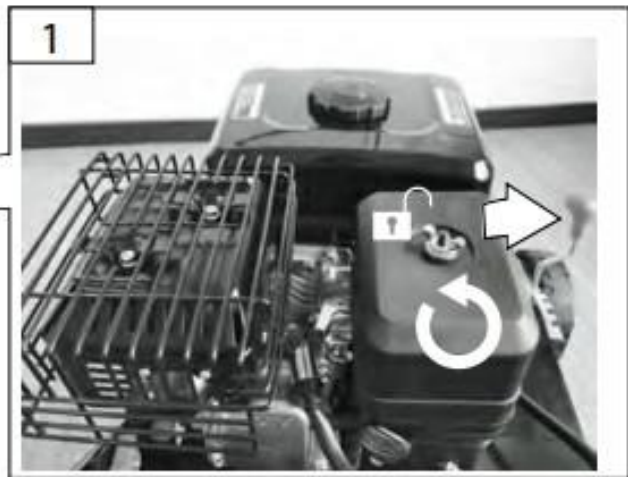

Le filtre en papier doit être nettoyé uniquement à l'air comprimé !  
N'utilisez jamais d'eau !

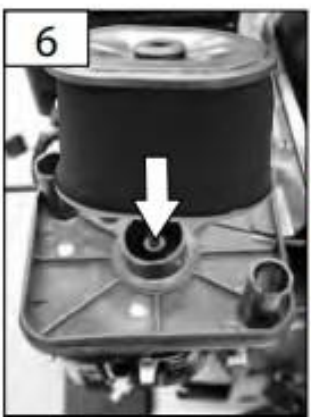

## Fiche technique

### Scarificateur-aérateur pour le gazon

Art. n° ..... **PS 700-25**

 Cylindrique ..... 208 cm<sup>3</sup>

 Puissance  
moteur 4 temps OHV..... 4,3 kW (5,8 PS)

 Régime nominal ..... 3600 min<sup>-1</sup>

 Largeur de travail ..... 400 mm

 Profondeur de travail .....  
..... -15 / -10 / 0 / +10 / +15 mm

 Capacité du bac de ramassage ..... 50 L

 Capacité du réservoir ..... 3,6 L  
Essence sans plomb SP95/SP98

 Poids ..... 35 kg

### Émissions sonores / Vibrations

 Niveau de pression acoustique pondérée LpA . 86,5 dB (A)

 Niveau de puissance acoustique LWA ..... 103 dB (A)

### Portez des protections auditives !

Valeur d'émission de vibrations ..... 4,34 m/s<sup>2</sup>  
K = 1,5 m/s<sup>2</sup>

Mesurage conforme à 1) EN 836 2) 2000/14/CE

**AVERTISSEMENT :** Le niveau d'émission de vibrations varie en fonction de l'utilisation de la machine et peut augmenter par rapport au niveau indiqué sur cette fiche technique.

Le niveau d'émission de vibrations peut être utilisé pour comparer une machine à une autre.

Il peut être utilisé pour une évaluation préliminaire de l'exposition.

Une estimation du niveau d'exposition aux vibrations devrait également tenir compte des moments où l'appareil est éteint ou lorsqu'il est en fonctionnement, mais inutilisé.

Cela peut réduire considérablement le niveau d'exposition pendant la session de travail globale.

Adoptez des mesures de sécurité supplémentaires pour protéger l'opérateur contre les effets des vibrations, par exemple : entretenez régulièrement la machine et ses équipements, gardez vos mains au chaud, organisez les opérations de travail.

 Lisez et comprenez les consignes de sécurité avant d'utiliser la machine.

 Familiarisez-vous avec les composants de commande et la bonne utilisation de l'appareil.

Respectez toutes les consignes de sécurité indiquées dans le manuel d'entretien.

Comportez-vous de manière responsable à l'égard des autres.

L'opérateur est responsable des accidents ou des risques causés à des tiers.

Si vous avez des doutes sur la connexion et le fonctionnement de cette machine, veuillez contacter notre service après-vente.

### Réduction du bruit

Gardez à l'esprit qu'un certain niveau de bruit généré par cet appareil est inévitable. Effectuez les travaux les plus bruyants pendant les heures spécifiées et autorisées.

Respectez les périodes de silence exigées par la loi et limitez la durée du travail au minimum nécessaire.

Pour protéger vous-même et votre entourage, il faut que vous portiez des protections auditives appropriées.

### Conditions d'utilisation

Ce scarificateur-aérateur est conçu pour scarifier et aérer les zones de petite et moyenne taille recouvertes de gazon autour des maisons et sur les parcelles de terrain.

Le scarificateur-aérateur ne doit pas être utilisé à d'autres fins, car il peut entraîner un risque de dommages corporels pour l'utilisateur et les autres personnes.

N'utilisez pas ce produit d'une manière autre que celle pour laquelle il a été conçu.

Le non-respect de la réglementation générale en vigueur et des instructions contenues dans ce manuel dégage le fabricant de toute responsabilité en cas d'endommagements.

 **Utilisez la machine uniquement à l'extérieur, ne l'utilisez jamais dans des zones confinées ou mal ventilées.**

 **Le scarificateur-aérateur ne doit être utilisé ni pour tailler des buissons, des haies et des arbustes, ni pour couper et broyer des plantes grimpantes, ni pour tondre du gazon sur des toitures végétalisées ou dans les jardinières. De plus, le scarificateur-aérateur ne doit être utilisé ni pour broyer des arbres ou des haies, ni pour niveler des surfaces irrégulières.**

### Exigences applicables au personnel opérationnel

Ne permettez jamais aux enfants d'utiliser cette machine.

Ne laissez pas des adultes travailler avec cette machine sans qu'ils aient été correctement formés.

Avant d'utiliser l'appareil, le personnel doit lire attentivement les instructions d'utilisation.

**Qualifications :** outre les instructions détaillées fournies par un spécialiste, aucune qualification particulière n'est requise pour faire fonctionner l'appareil.

**Âge minimal :** seules les personnes de plus de 16 ans peuvent utiliser la machine. Font exception les jeunes qui sont formés pour acquérir des connaissances sous la supervision du responsable de la formation professionnelle. Les réglementations locales peuvent fixer l'âge minimal de l'utilisateur.

**Formation :** l'utilisation de l'appareil exige uniquement une formation appropriée dispensée par un spécialiste ou par le manuel d'utilisation. Aucune formation spéciale n'est requise.

## Risques résiduels

**⚠ Les lames rotatives peuvent provoquer des blessures graves, des coupures ou des amputations des parties de votre corps.**

Ne touchez jamais le dessous du corps du logement lorsque le moteur est en fonctionnement.

Portez des chaussures de sécurité. Ne retirez jamais le bac de ramassage lorsque la machine est en fonctionnement.

**⚠ Des pierres ou de la terre peuvent provoquer des blessures si elles sont projetées hors de la machine.**

Veillez à ce que le bac de ramassage soit bien suspendu. Portez des lunettes de protection pendant la session de travail.

**⚠ Un éclairage faible représente un risque élevé pour la sécurité.**

Prévoyez un éclairage adéquat ou de bonnes conditions de visibilité lorsque vous travaillez avec cette machine.

## Procédures d'urgence

**⚠ Danger de blessures !**

Ne mettez ni vos mains ni vos pieds près ou en dessous des pièces rotatives.

Tenez-vous à une distance de sécurité de l'ouverture du pot d'échappement.

**⚠ Danger de brûlures !**

Certaines pièces de la machine surchauffent pendant le fonctionnement.

Ne touchez pas les pièces brûlantes. Par exemple, le moteur et le pot d'échappement.

Effectuez la procédure de premiers soins adaptée au type de blessure et appelez le personnel médical qualifié aussitôt que possible.

Protégez la personne blessée contre d'autres dommages corporels et rassurez-la.

Pour faire face à un accident, conformément à la norme DIN13164, un lieu de travail doit être équipé d'une trousse de secours. Il est essentiel que le matériel de la trousse de secours soit remplacé immédiatement après utilisation.

En cas de demande d'aide, veuillez fournir les informations suivantes :

1. Lieu de l'accident ;
2. Type d'accident ;
3. Nombre de blessés ;
4. Type de lésion(s).

## Symboles



Attention !



Lisez attentivement les instructions



Portez des protections auditives !  
Portez des protections oculaires !



Attention : les lames descendent. Attendez que toutes les pièces mobiles soient à l'arrêt.



Attention : surface brûlante !  
Danger de brûlures !



Attention aux objets projetés !



Gardez les passants à distance !  
Respectez les consignes de sécurité pour éviter de vous trouver dans une zone dangereuse.



Avant d'effectuer toute intervention sur le moteur, arrêtez-le et débranchez la fiche de la prise de courant.



Gardez une distance suffisante des lames de coupe pendant le fonctionnement.



Attention : risque de coincement !



Risque d'explosion !



Ravitaillez le moteur uniquement lorsqu'il est à l'arrêt.



Risque d'empoisonnement !



Utilisez la machine uniquement à l'extérieur, ne l'utilisez jamais dans des zones confinées ou mal ventilées.



Il vous est interdit de fumer et d'utiliser des flammes nues.



Gardez toujours les enfants et les personnes non autorisées à l'écart de la machine.



N'exposez pas la machine à la pluie et ne l'utilisez pas dans des conditions d'humidité.



Portez des chaussures résistantes aux coupures munies d'une semelle de sécurité et d'un embout de protection en acier !

# AGRIEURO

Fraz. Petrognano, 50/D - 06049 - Spoleto - PG- Italy  
Reg. imprese di Perugia - C.F. / P. IVA (VAT code) IT01629170547

## DÉCLARATION DE CONFORMITÉ UE

La présente déclaration de conformité est délivrée sous la seule responsabilité du fabricant :

**AGRIEURO SRL**  
**Fraz. Petrognano 50/D - 06049 Spoleto (PG) – Italie**

Objet de la déclaration :

<b>PRODUIT</b>	SCARIFICATEURS POUR GAZON
<b>MARQUE</b>	GREENBAY
<b>MODÈLE(S)</b>	FCP400
<b>CODE(S)</b>	112731
<b>NOM(S)</b>	PS 700-25

L'objet de la déclaration visée ci-dessus est conforme à la législation d'harmonisation de l'Union applicable :

- Directive 2006/42 CE
- Directive 2014/30 UE
- Directive 2000/14 telle que modifiée par la directive 2005/88 CE

aux normes harmonisées suivantes :

- EN 13684:2018
- EN ISO 14982:2009
- EN 3744:1995
- ISO 11094:1991

Nous confirmons également ce qui suit, conformément à la directive 2000/14/CE relative aux émissions telle que modifiée par la directive 2005/88/CE :

- Le niveau de puissance acoustique mesuré sur un équipement représentatif du type couvert par la déclaration de conformité est de : 94 dB(A).
- Le niveau de puissance acoustique garantie pour l'équipement est de : 96 dB(A).

Signé au nom et pour le compte de : ALESSIA  
SETTIMI

À SPOLETO

Signature

Le 21/05/2025

**AGRIEURO** SRL  
FRAZ. PETROGNANO 50/D - SPOLETO (PG)  
C.F. B.P.IVA 01629170547



**Übersetzung der  
originalen  
BEDIENUNGSANLEITUNG  
Vertikutierer für Rasenflächen  
PS 700-25  
cod. 112731**



Lesen Sie diese Anleitung sorgfältig durch, bevor Sie das Gerät verwenden.



 **GREENBAY**



AGRIEURO s.r.l.  
Fraz. Petrognano, 50/D - 06049 Spoleto (PG) - Italia

CE



# LISTE DER BAUTEILE



1



2



3



4

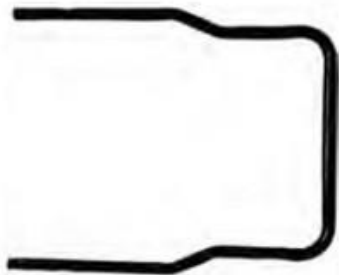

5



6



2x

7



4x

8



Montage



2-3

Starten der Maschine



4-8

Anweisungen zum  
Schneiden



9

Betrieb



10

Reinigung und  
Wartung





11-15



# 1 Montage

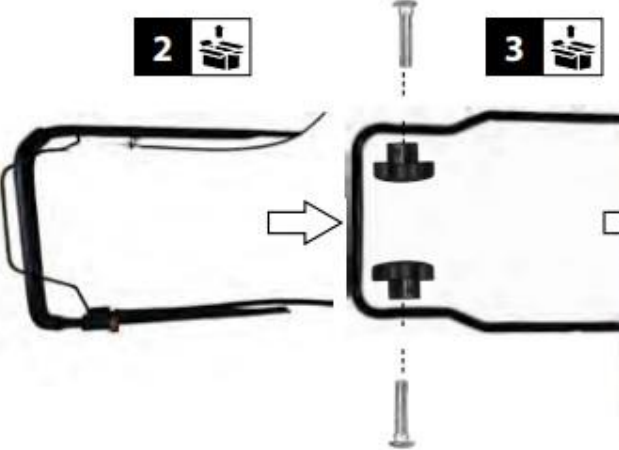

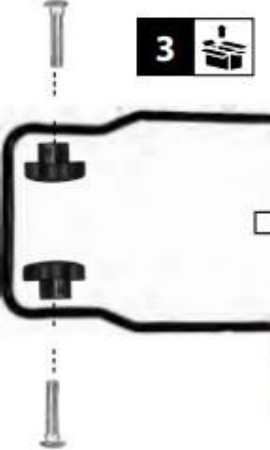

**1**

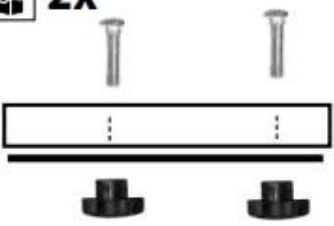

**2**  

**3**  

**4**  **2x**  

**5**  **2x**

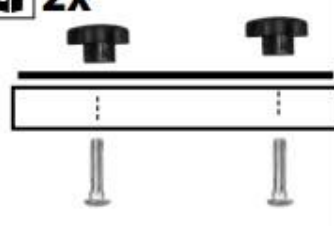
**6**  **2x**

**4**  **2x**  

Montage



3



2

Montierte Maschine





# Einstellen des Schnittwinkels

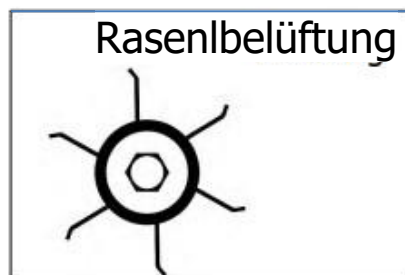
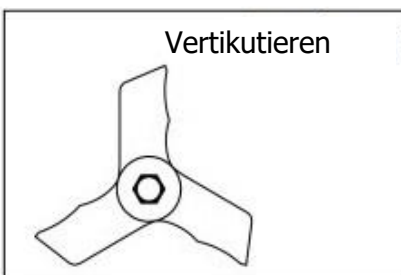
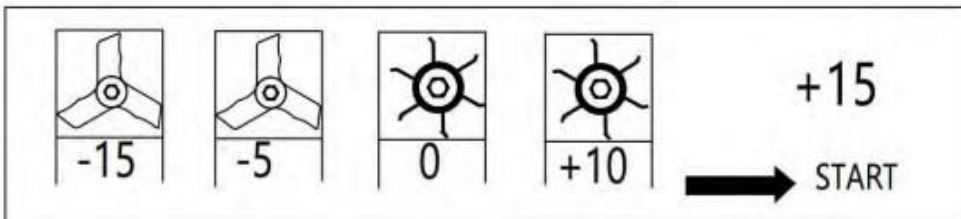
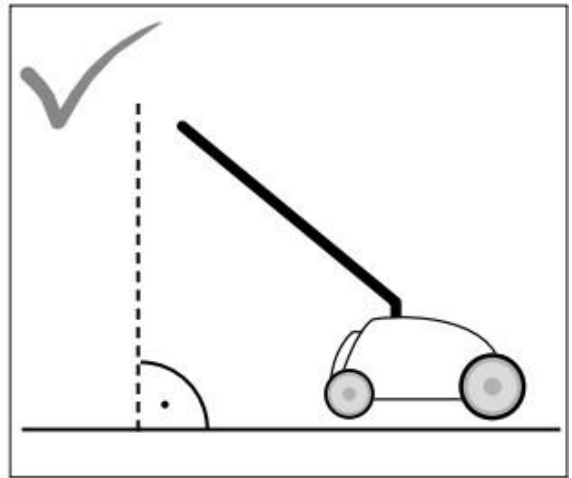

# Kontrolle des Ölstandes



**10W-40**

Prüfen Sie den Ölstand jedes Mal, wenn das Gerät in Betrieb genommen werden soll. Gegebenenfalls Motoröl nachfüllen.

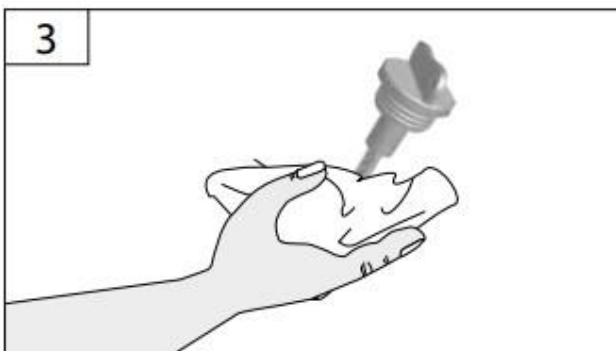
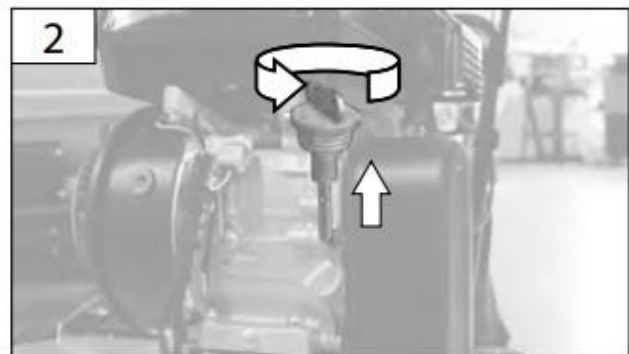
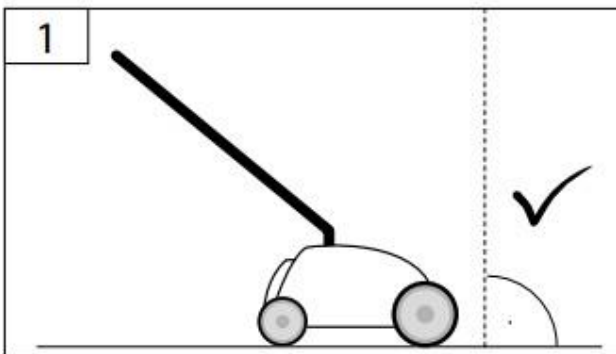



## Kontrolle des Ölstandes

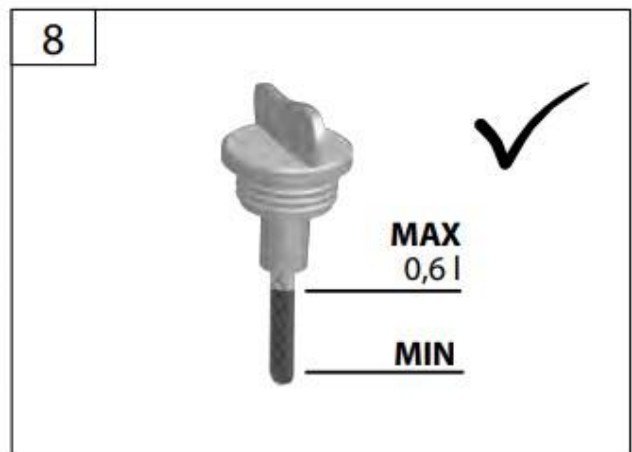
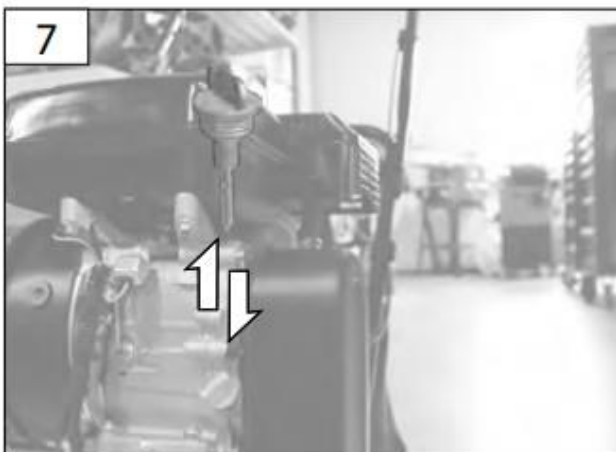
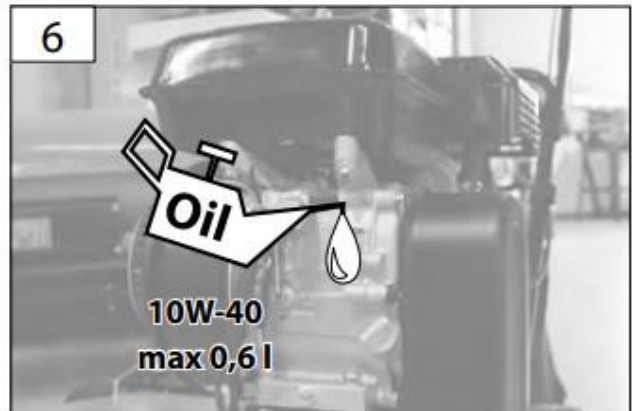
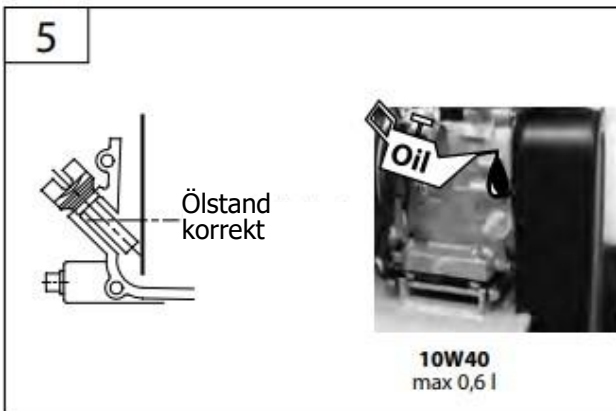

## Kontrolle des Ölstandes



7



**Um die Qualität zu gewährleisten, wird jedes Gerät geprüft und mit Motoröl befüllt.**

**Das Öl wird vor dem Transport abgelassen; es kann jedoch etwas Motoröl am Peilstab zurückbleiben.**

**Prüfen Sie den Ölstand sorgfältig und füllen Sie erneut Motoröl ein. 5 - 6**



## Nachfüllen des Kraftstofftanks

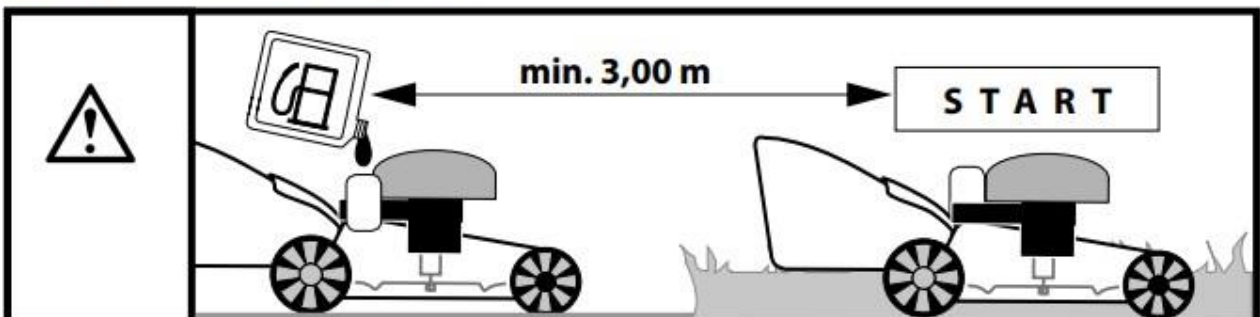
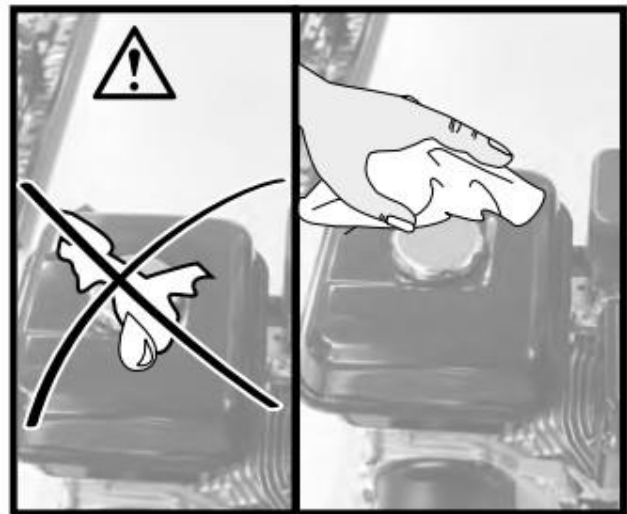
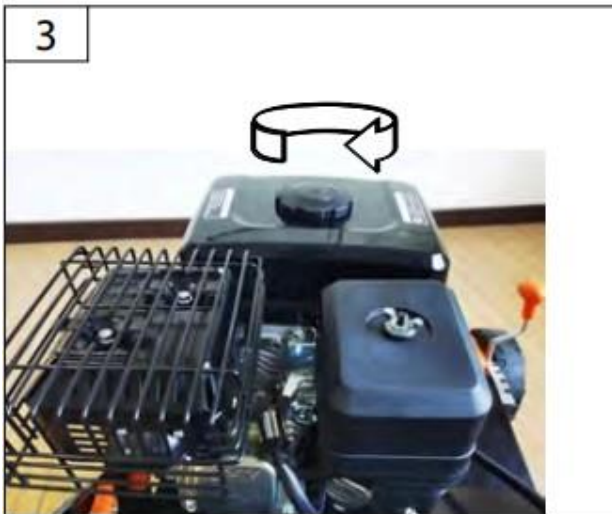
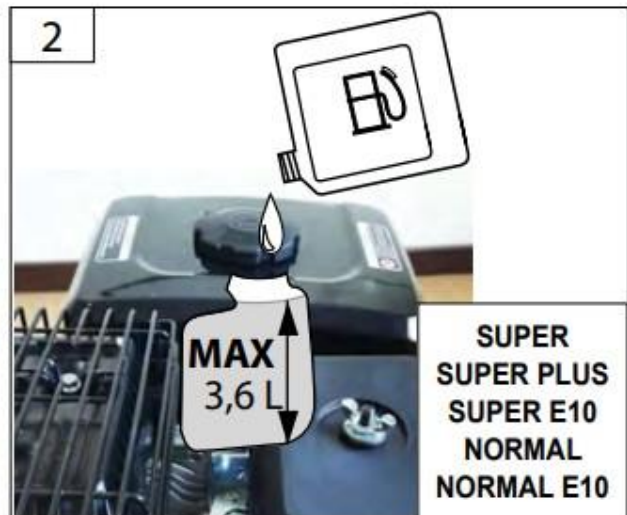
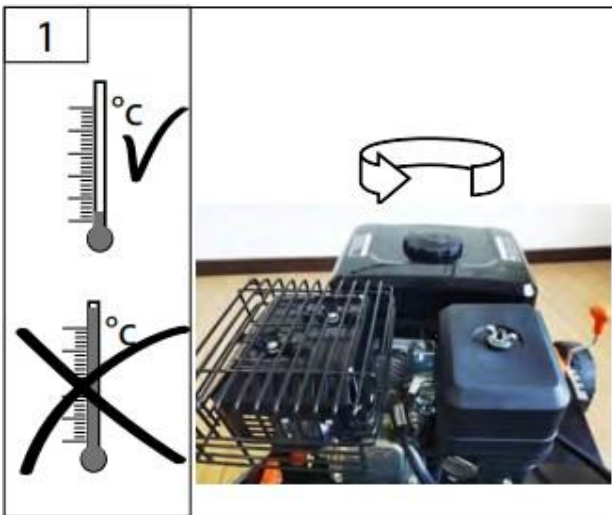

# Anweisungen zum Schneiden

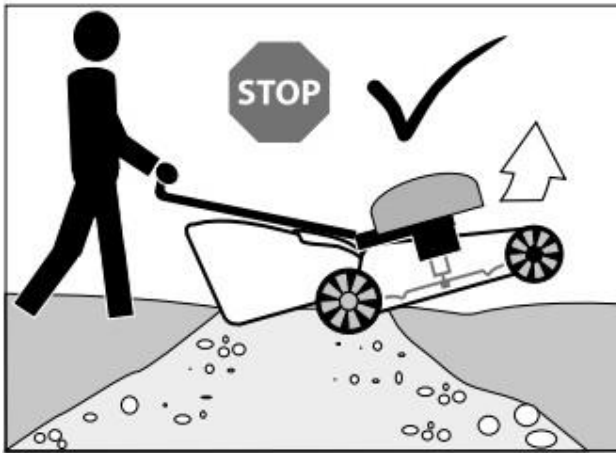
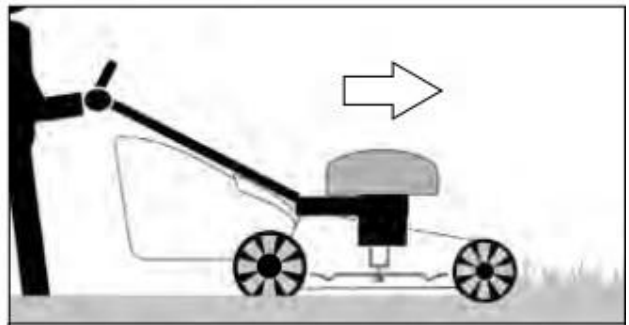
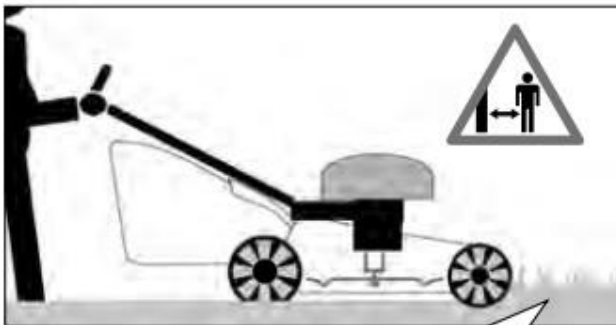

START  
4  
STOP

Betrieb

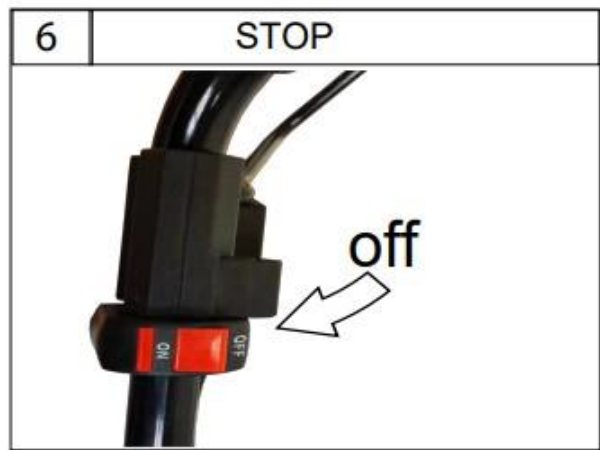
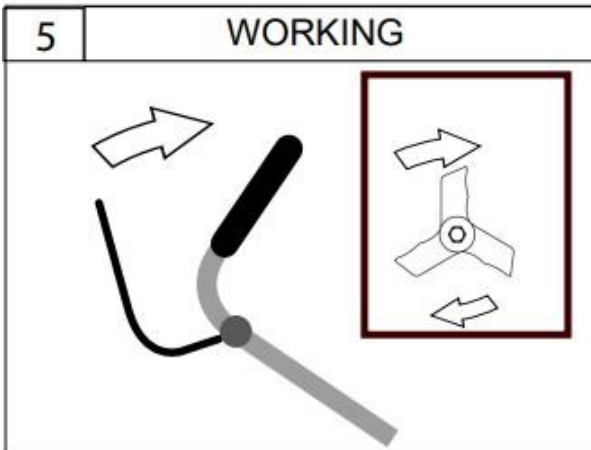
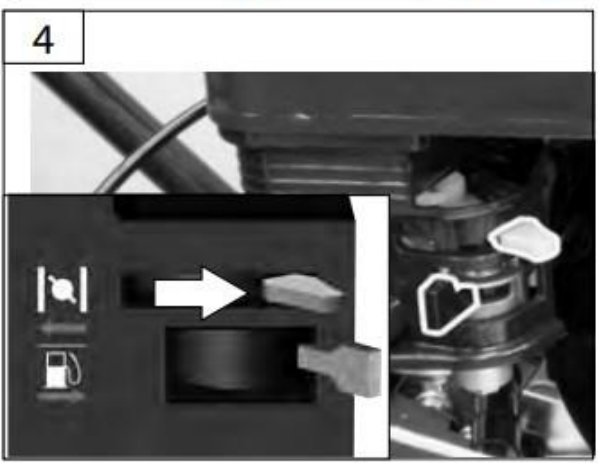
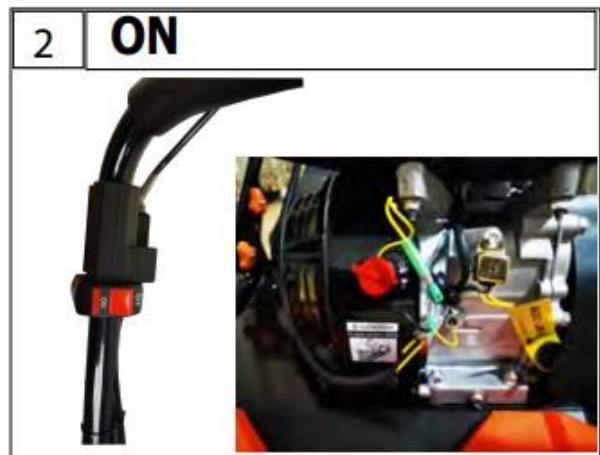
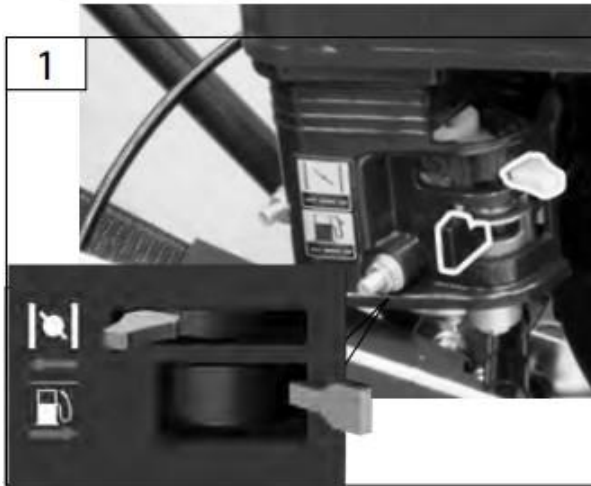

# Reinigung und Wartung

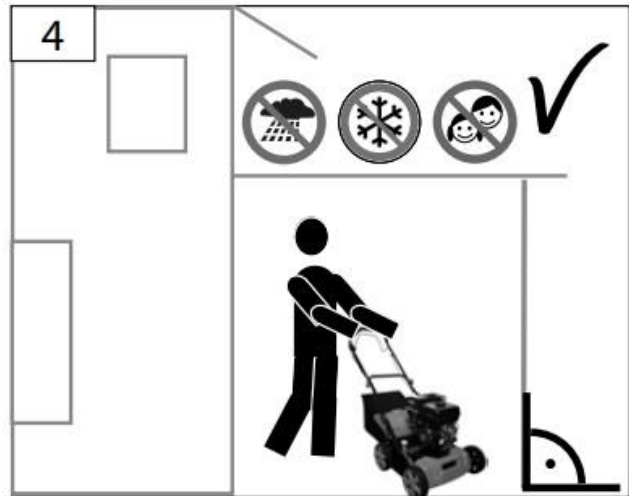
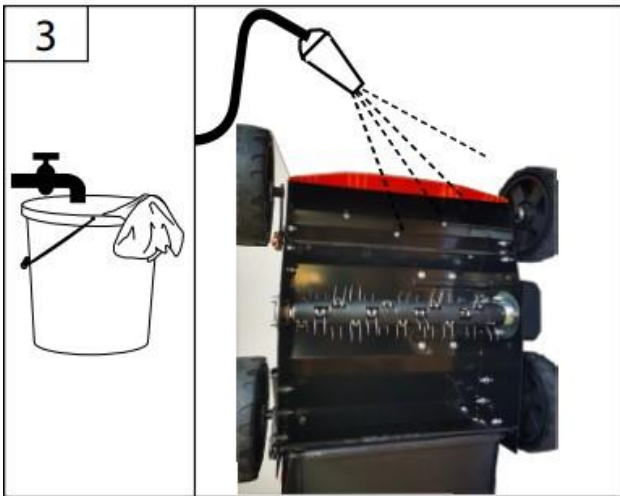
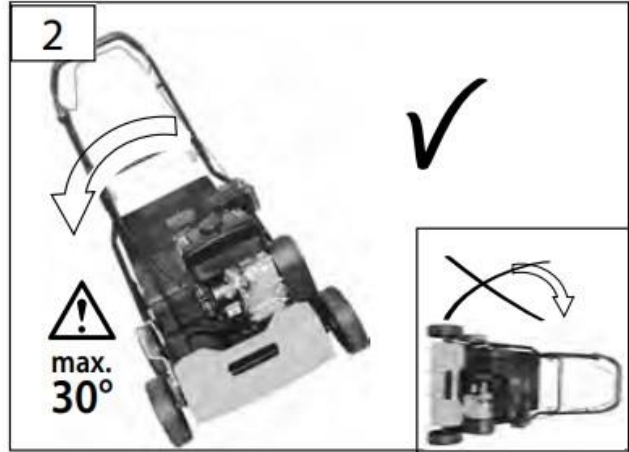

# 5 Reinigung und Wartung

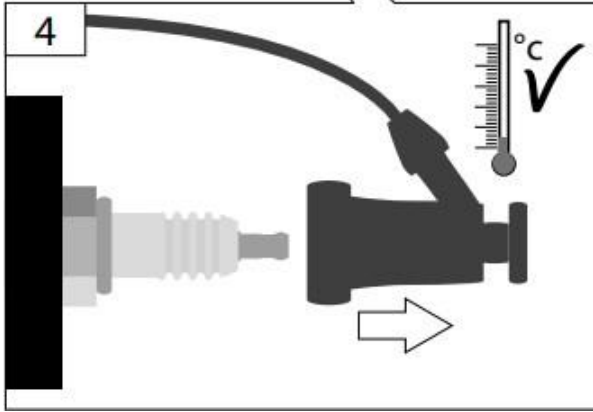
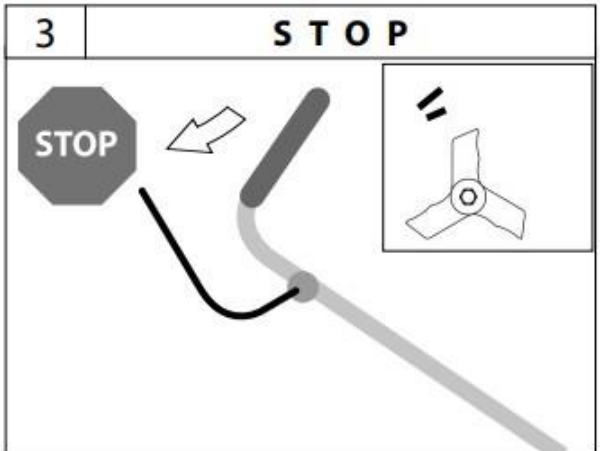
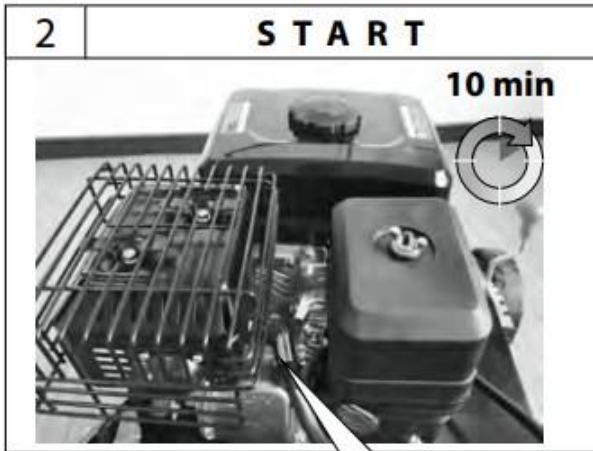
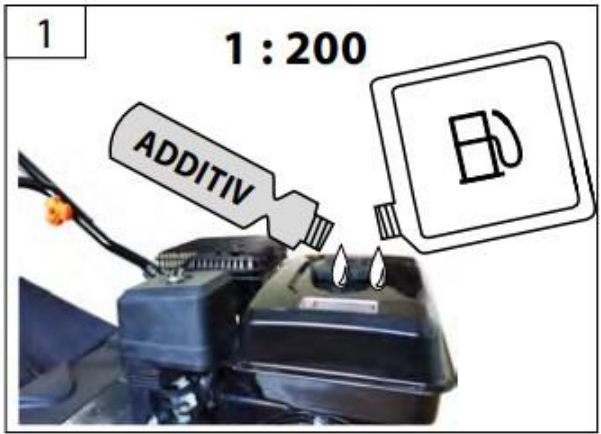
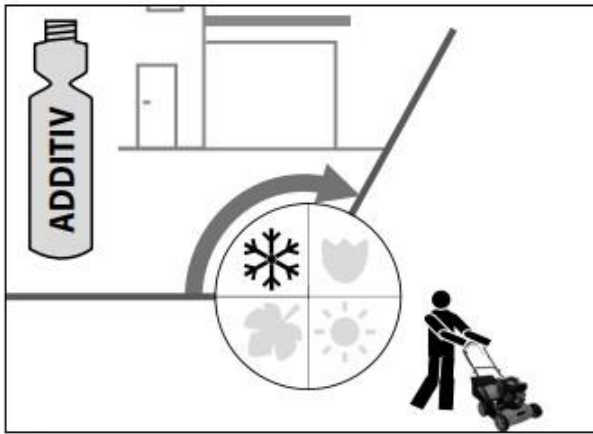

# Zündkerze

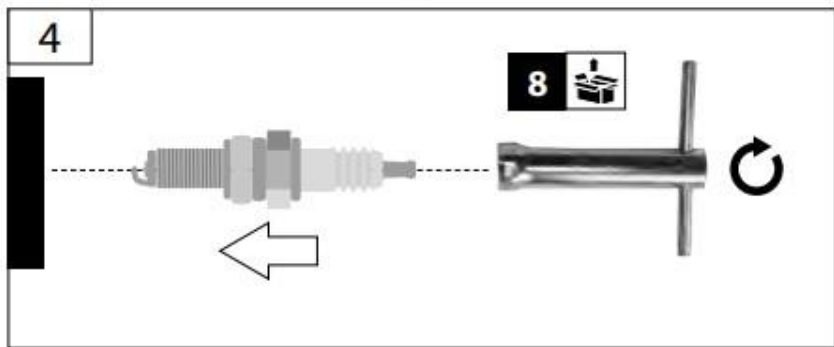
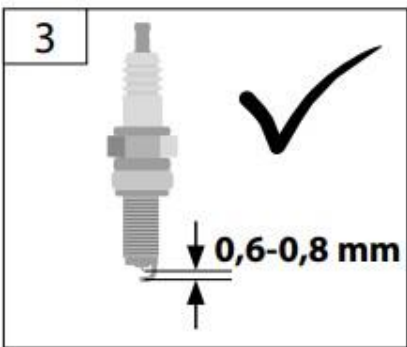
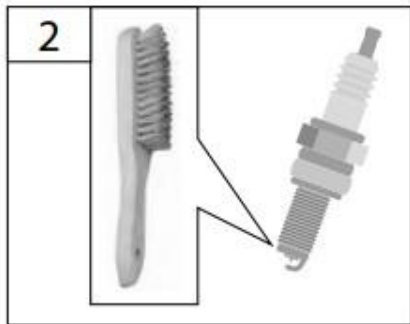
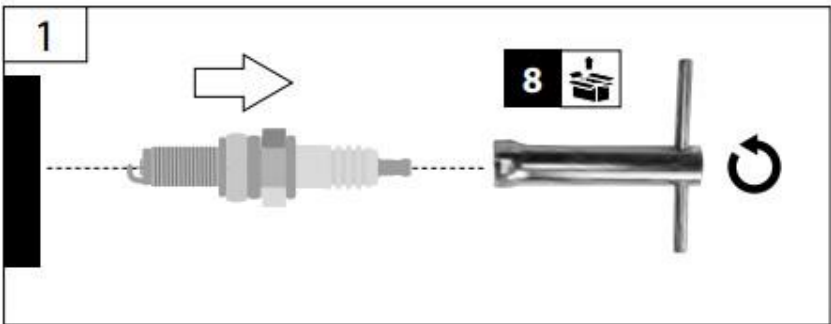
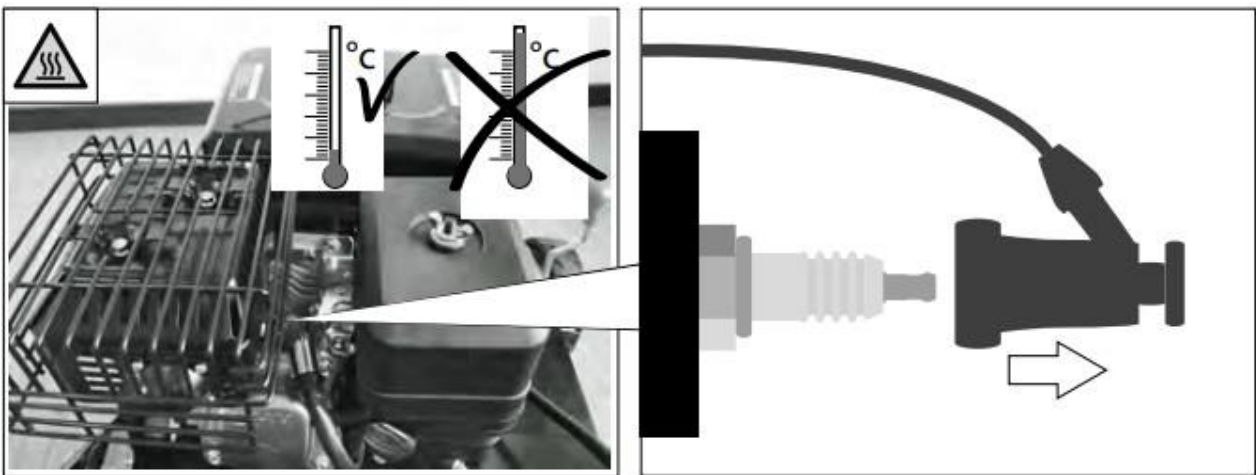



# Ölwechsel

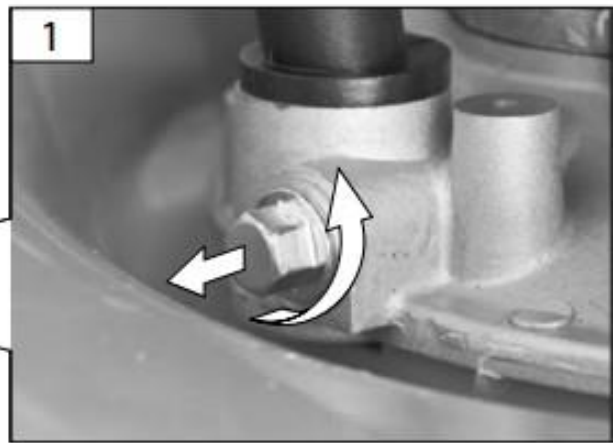
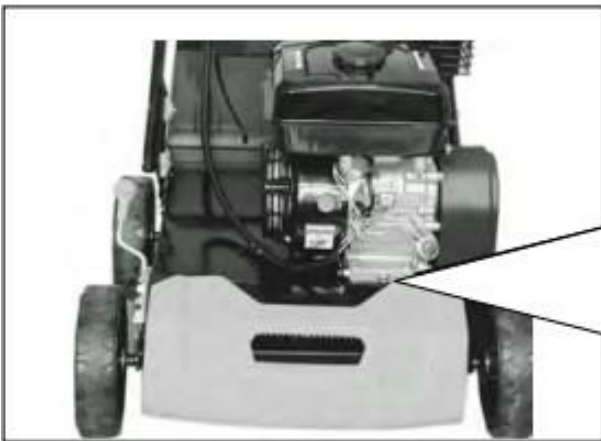

# Luftfilter

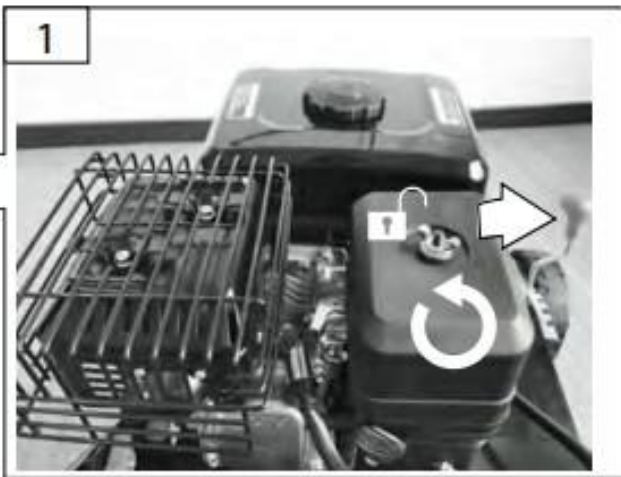

Der Papierfilter darf nur mit Druckluft gereinigt werden!  
Niemals Wasser verwenden!



## Technisches Datenblatt

**Vertikutierer für Rasenflächen**Art. No. **PS 700-25**

	Hubraum.....	208cm <sup>3</sup>
	Leistung 4-Takt ÖHV-Motor .....	4.3 kW (5,8 PS)
	Nennzahl.....	3600 min <sup>-1</sup>
	Schnittbreite.....	400 mm
	Schnitttiefe .....	-15 / -10 / 0 / +10 / +15 mm
	Fassungsvermögen des Fangbehälters.....	50 L
	Fassungsvermögen des Tanks.....	3,6 L
	Superbenzin / Bleifrei / E10	
	Gewicht.....	35 kg

**Informationen bezüglich Lärm / Vibrationen**

	Gewichteter Schalldruckpegel LpA .....	86,5 dB (A)
	Schalleistungspegel LWA .....	103 dB (A)

**! Tragen Sie einen Gehörschutz!**! Wert der Schwingungsemission----- 4.34 m/s<sup>2</sup>K=1,5 m/s<sup>2</sup>

Messung nach 1) EN 836 2) 2000/14/EG

**WARNUNG:** Der Schwingungsemissionspegel variiert aufgrund der Art der Nutzung der Maschine und kann im Vergleich zu den in diesem Datenblatt angegebenen Werten ansteigen.

Der Schwingungsemissionspegel kann dazu verwendet werden, eine Maschine mit einer anderen zu vergleichen. Er kann für eine vorläufige Expositionsbeurteilung verwendet werden. Bei der Abschätzung der Vibrationsexposition sollten auch die Zeiten berücksichtigt werden, in denen das Gerät ausgeschaltet ist oder zwar läuft, aber nicht in Bewegung ist.

Dies kann u. U. kann sich das Expositionsniveau während der gesamten Arbeitsdauer erheblich reduzieren. Ergreifen Sie zusätzliche Sicherheitsmaßnahmen, um den Bediener vor den Auswirkungen von Vibrationen zu schützen, wie z. B.: regelmäßige Wartung des Gerätes und des Zubehörs, Warmhalten der Hände, Planung der Arbeitsabläufe.



Lesen und verstehen Sie die Anweisungen und Sicherheitshinweise, bevor Sie die Maschine benutzen

Machen Sie sich mit den Bedienelementen und dem korrekten Gebrauch der Maschine vertraut.

Beachten Sie alle im Wartungshandbuch angegebenen Sicherheitsmaßnahmen.

Verhalten Sie sich verantwortungsbewusst gegenüber Dritten.

Für Unfälle oder Gefahren für Dritte ist der Betreiber verantwortlich.

Bei Unklarheiten über Anschluss und Betrieb wenden Sie sich bitte an unseren Kundendienst.

**Informationen zur Geräuschdämmung**

Ein gewisser Geräuschpegel, der von diesem Gerät erzeugt wird, ist unvermeidbar. Führen Sie sehr lärmintensive Arbeiten zu den zugelassenen und festgelegten Zeiten durch.

Halten Sie die gesetzlich vorgeschriebenen Ruhezeiten ein und beschränken Sie die Dauer der Arbeiten auf das unbedingt notwendige Maß.

Zum Schutz der eigenen Person und der Personen in Ihrer Umgebung muss ein geeigneter Gehörschutz getragen werden.

**Besondere Bedingungen für die Verwendung**

Der Vertikutierer ist für das Vertikutieren und Belüften kleiner bis mittelgroßer Rasenflächen im Haus- und Kleingartenbereich konzipiert.

Der Vertikutierer darf nicht für andere Zwecke verwendet werden, da er eine Verletzungsgefahr für den Benutzer und andere Personen darstellen kann.

Dieses Produkt darf nur für den bestimmungsgemäßen Gebrauch verwendet werden. Die Nichteinhaltung der geltenden allgemeinen Vorschriften und der in dieser Anleitung enthaltenen Anweisungen schließt die Haftung des Herstellers für Schäden aus.



**Verwenden Sie das Gerät nur im Freien, niemals in geschlossenen und schlecht belüfteten Räumen.**



**Der Vertikutierer darf nicht zum Beschneiden von Büschen, Hecken und Sträuchern, zum Schneiden und Häckseln von Schlingpflanzen oder Rasen auf begrüntem Dächern oder in Balkonkästen verwendet werden. Außerdem darf der Vertikutierer nicht als Häcksler zum Zerkleinern von Bäumen und Hecken oder zum Ausgleichen von Unebenheiten verwendet werden.**

**Anforderungen an das Bedienpersonal**

Das Gerät darf niemals von Kindern in Betrieb genommen werden.

Lassen Sie Erwachsene nur dann mit der Maschine arbeiten, wenn sie entsprechend geschult sind.

Vor der Benutzung der Maschine muss das Personal die Betriebsanleitung sorgfältig lesen.

**Ausbildung:** Abgesehen von einer ausführlichen Einweisung durch einen Fachmann sind für die Nutzung des Gerätes keine besonderen Qualifikationen erforderlich.

**Mindestalter:** Die Maschine darf nur von Personen bedient werden, die mindestens 16 Jahre alt sind. Eine Ausnahme bilden Jugendliche, die unter Aufsicht des Ausbildungsleiters Kenntnisse erwerben sollen. Das Mindestalter des Benutzers kann durch örtliche Vorschriften festgelegt werden.

**Schulung:** Die Verwendung des Gerätes erfordert lediglich eine entsprechende Unterweisung durch einen Fachmann oder das Benutzerhandbuch. Es ist keine besondere Ausbildung erforderlich.

## Restrisiken

### ⚠ Rotierende Messer können schwere Verletzungen durch Schneiden oder Amputieren von Körperteilen verursachen.

Bei laufendem Motor niemals unter das Gehäuse greifen. Tragen Sie Sicherheitsschuhe. Entfernen Sie niemals den Fangsack, wenn die Maschine läuft.

### ⚠ Steine oder Erde können Verletzungen verursachen, wenn sie aus der Maschine geschleudert werden.

Stellen Sie sicher, dass der Fangsack richtig eingehängt ist.

Tragen Sie bei der Arbeit mit dem Gerät eine Schutzbrille.

### ⚠ Schlechte Beleuchtung stellt ein hohes Sicherheitsrisiko dar.

Sorgen Sie für eine ausreichende Beleuchtung oder gute Lichtverhältnisse während des Maschinenbetriebs.

## Notfallverfahren

### ⚠ Verletzungsgefahr!

Legen Sie Ihre Hände oder Füße nicht in die Nähe oder unter rotierende Teile. Halten Sie einen Sicherheitsabstand zum Auswurfkaminschacht

### ⚠ Verbrennungsgefahr!

Einige Teile des Geräts werden während des Betriebs heiß. Berühren Sie keine heißen Teile. Zum Beispiel den Motor und den Schalldämpfer.

Führen Sie je nach Art der Verletzung eine Erste-Hilfe-Maßnahme durch und rufen Sie so schnell wie möglich qualifiziertes medizinisches Personal. Schützen Sie die verletzte Person vor weiteren Verletzungen und beruhigen Sie sie. Um einem möglichen Unfall begegnen zu können, muss ein Arbeitsplatz mit einem Erste-Hilfe-Kasten nach DIN 13164 ausgestattet sein. Es ist wichtig, dass das Material des Erste-Hilfe-Kastens sofort nach Gebrauch ersetzt wird.

Im Falle einer Anfrage um Hilfe, geben Sie bitte folgende Informationen an:

1. Ort des Unfalls;
2. Art des Unfalls;
3. Anzahl der verletzten Personen;
4. Art der Verletzung(en).

## Symbole



Achtung!



Die Bedienungsanleitung sorgfältig lesen



Tragen Sie einen Gehörschutz!  
Tragen Sie einen Augenschutz!



Achtung: Die Messer werden abgesenkt. Warten Sie, bis alle beweglichen Teile zum Stillstand gekommen sind.



Gefahr - Heiße Oberflächen!  
Verbrennungsgefahr!



Vorsicht vor ausgeworfenen Gegenständen



Halten Sie unbefugte Personen auf Abstand!  
Beachten Sie die Sicherheitsregeln, um zu vermeiden, dass Sie sich in einem gefährlichen Bereich aufhalten.



Schalten Sie den Motor vor allen Arbeiten aus und ziehen Sie den Stecker aus der Steckdose.



Halten Sie während des Betriebs einen ausreichenden Abstand zum Schneidemesser.



Vorsicht, Einklemmgefahr!



Explosionsgefahr!



Betanken Sie den Motor nur wenn er abgestellt ist.



Vergiftungsgefahr!



Verwenden Sie das Gerät nur im Freien, niemals in engen, schlecht belüfteten Räumen verwenden.



Rauchen und offene Flammen sind verboten.



Halten Sie Kinder und unbefugte Personen stets von der Maschine fern



Setzen Sie das Gerät nicht dem Regen aus und verwenden Sie es nicht in nasser Umgebung.



Tragen Sie schnittfeste Schuhe mit Sicherheitssohlen<sup>1)</sup> und Stahlkappen!<sup>5)</sup>

## EU-KONFORMITÄTSERKLÄRUNG

Diese Konformitätserklärung wird unter der alleinigen Verantwortung des Herstellers ausgestellt:

**AGRIEURO SRL**  
**Fraz. Petrognano 50/D - 06049 Spoleto (PG) – Italy**

Gegenstand der Erklärung:

<b>PRODUKT</b>	VERTIKUTIERER
<b>MARKE</b>	GREENBAY
<b>MODELL/E</b>	FCP400
<b>CODE/CODES</b>	112731
<b>NAME/NAMEN</b>	PS 700-25

Der Gegenstand der vorstehenden Erklärung steht im Einklang mit den einschlägigen Harmonisierungsrechtsvorschriften der Europäischen Union:

- Richtlinie 2006/42 EG
- Richtlinie 2014/30 EU
- Richtlinie 2000/14 EG und deren Änderung Richtlinie 2005/88 EG

mit den folgenden harmonisierten Normen:

- EN 13684:2018
- EN ISO 14982:2009
- EN 3744:1995
- ISO 11094:1991

Darüber hinaus bestätigen wir in Übereinstimmung mit der Emissionsrichtlinie 2000/14/EG, geändert durch die Richtlinie 2005/88/EG, Folgendes:

- Der Schallleistungspegel, der an einem für den Typ, für den die Konformitätserklärung ausgestellt wurde, repräsentativen Gerät gemessen wurde, beträgt: 94 dB(A).
- Der garantierte Schallleistungspegel für das Gerät beträgt: 96 dB (A).

Unterzeichnet im Namen und Auftrag von:  
ALESSIA SETTIMI

Ort, SPOLETO

Datum 21/05/2025

Unterschrift

**AGRIEURO**<sup>SRL</sup>  
FRAZ. PETROGNANO 50/D - SPOLETO (PG)  
C.F. B P.IVA 01629170547



# MANUAL DE INSTRUCCIONES

## Escarificador de césped

PS 700-25

Cód. 112731



Lea el manual cuidadosamente antes de usar la maquina.



 **GREENBAY**



AGRIEURO s.r.l.

Frazione San Venanzo 11 - 06049 - Spoleto - PG - Italia





# LISTA DE PIEZAS

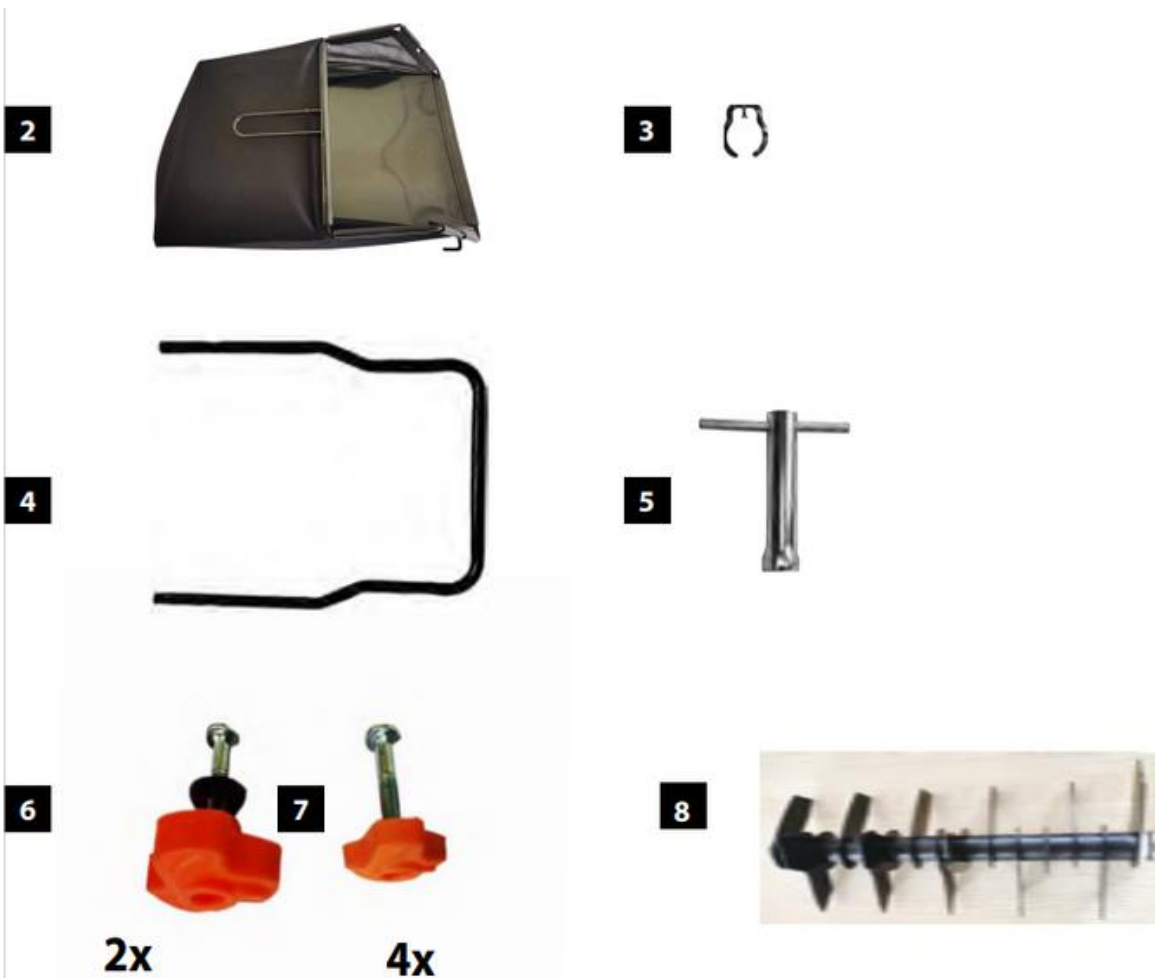

Montaje



2-3

Poner en marcha la máquina



4-8

Instrucciones de corte



9

Funcionamiento



10

Limpieza/mantenimiento



11-15

## Montaje

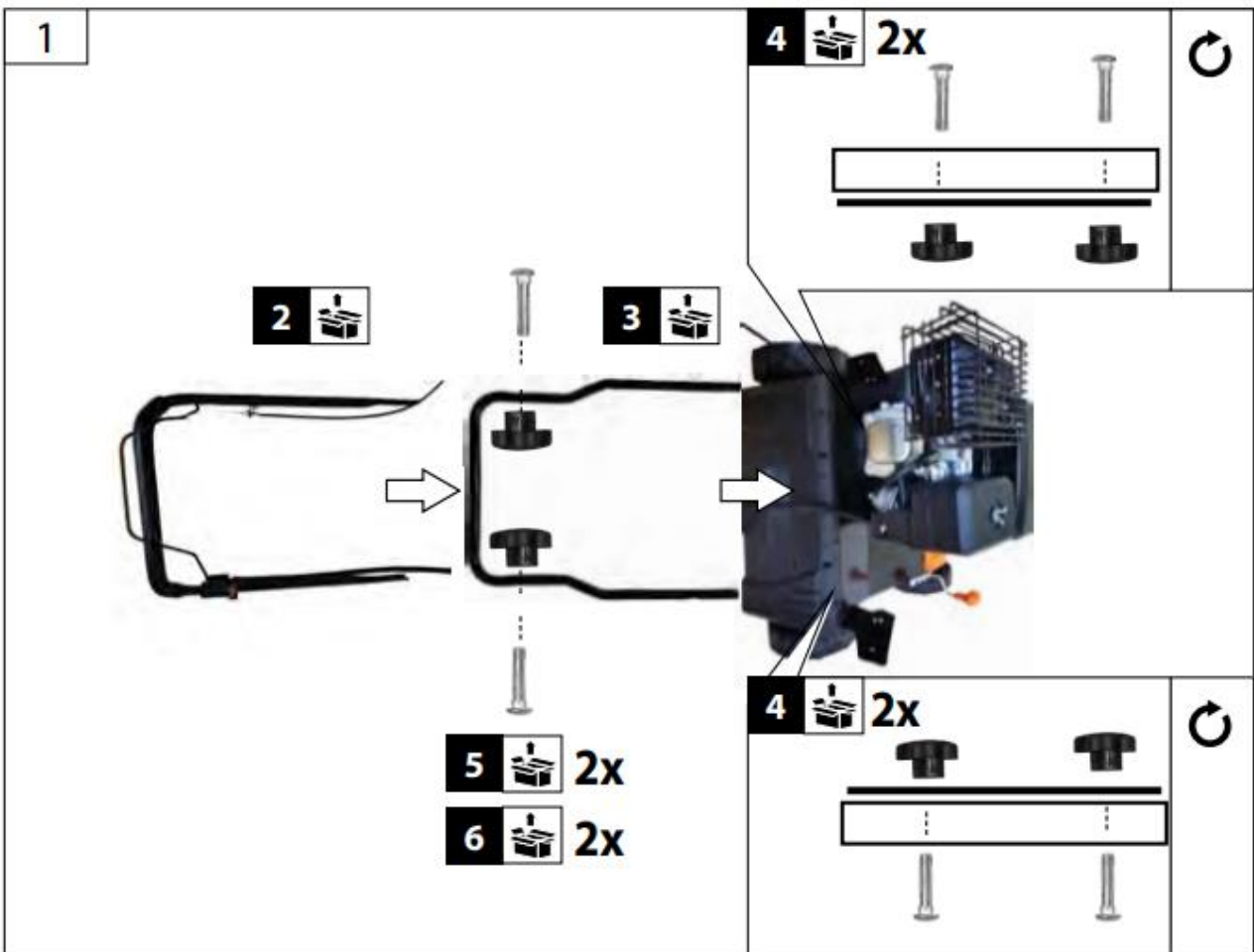
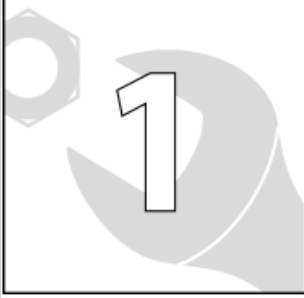

# Montaje



3



2

# Máquina montada





# Ajuste de altura de corte

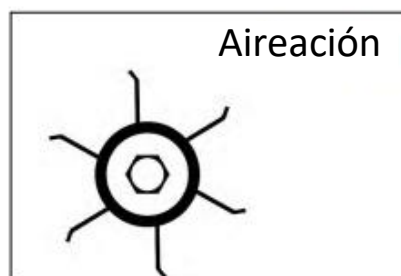
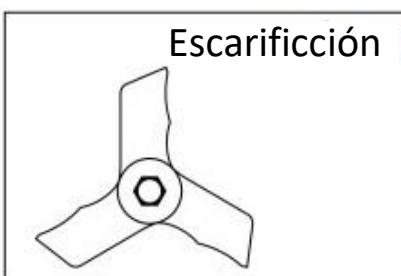
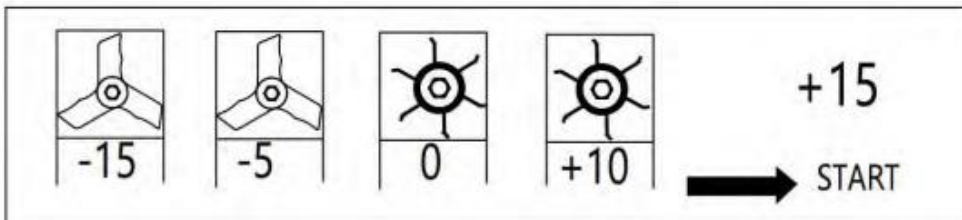
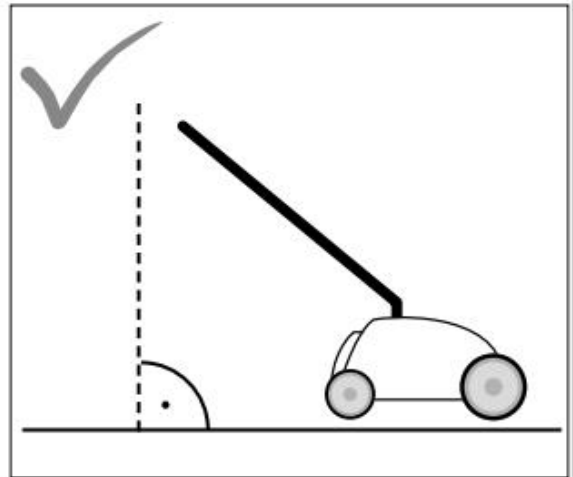

# Comprobación del nivel de aceite



**10W-40**

Compruebe el nivel de aceite cada vez que la máquina va a ser operada.

Si es necesario, añada aceite motor.

1

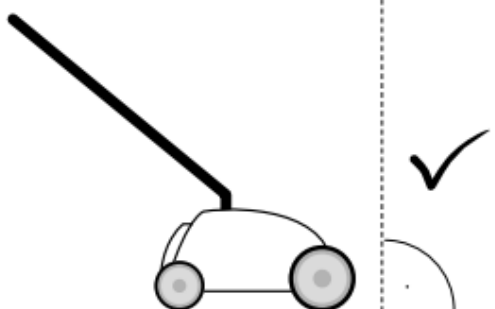

2

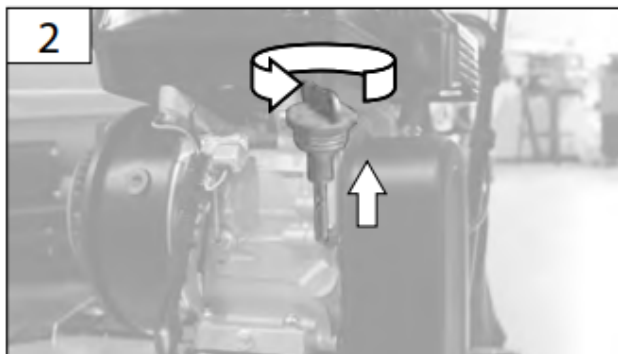

3



4



# Comprobación del nivel de aceite

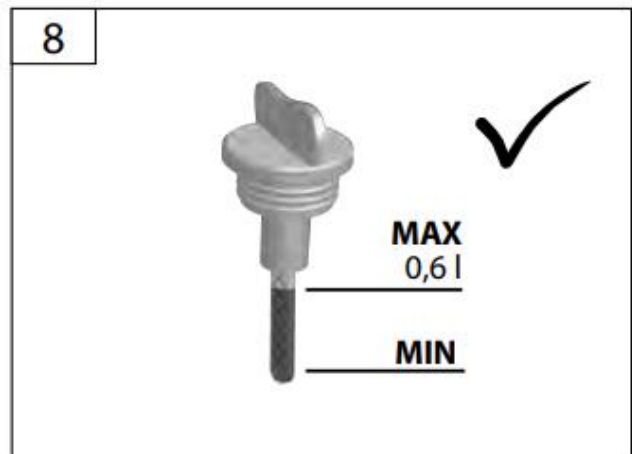
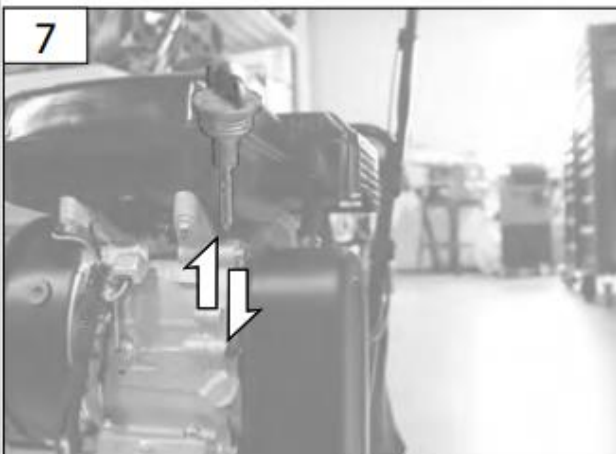
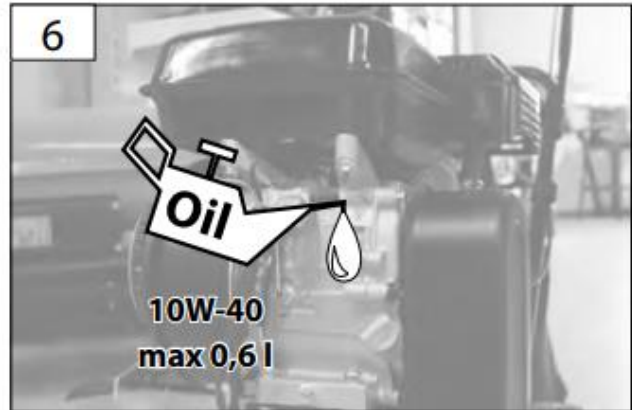
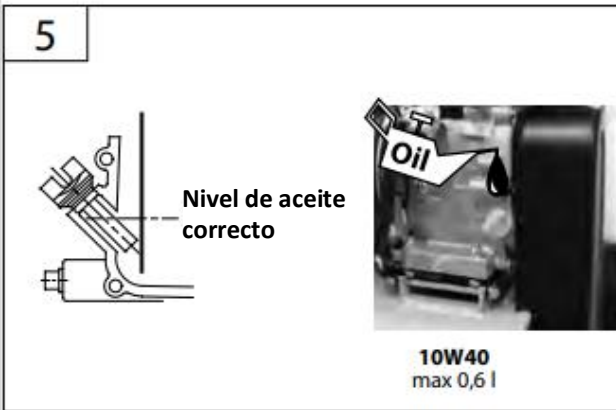

## Comprobación del nivel de aceite



7



**Para garantizar la calidad, cada unidad se prueba y se rellena con aceite de motor.**

**El aceite se drena antes del transporte; sin embargo, es posible que el aceite del motor gotee en la varilla de medición.**

**Compruebe cuidadosamente el nivel de aceite y vuelva a llenar el aceite del motor. 5 - 6**



## Repostaje del depósito de combustible

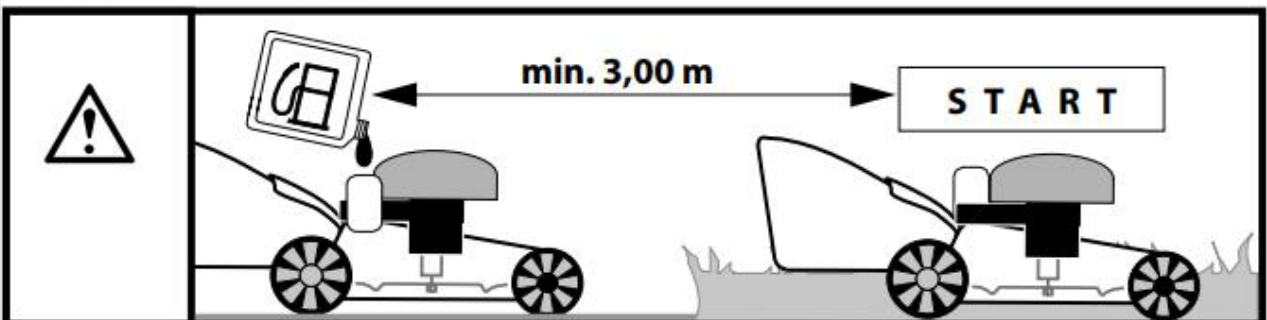
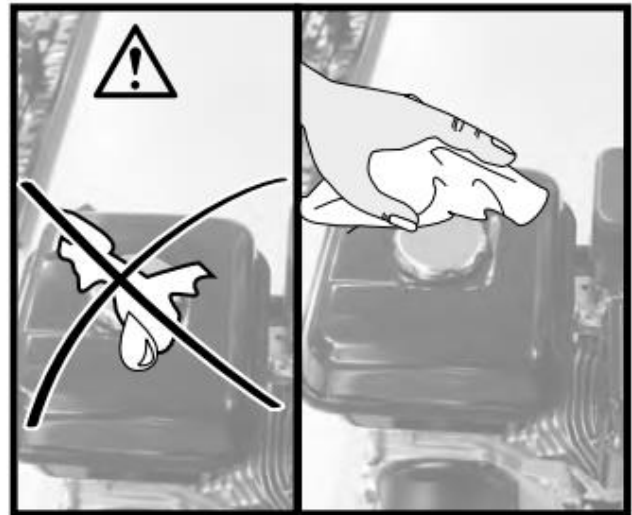
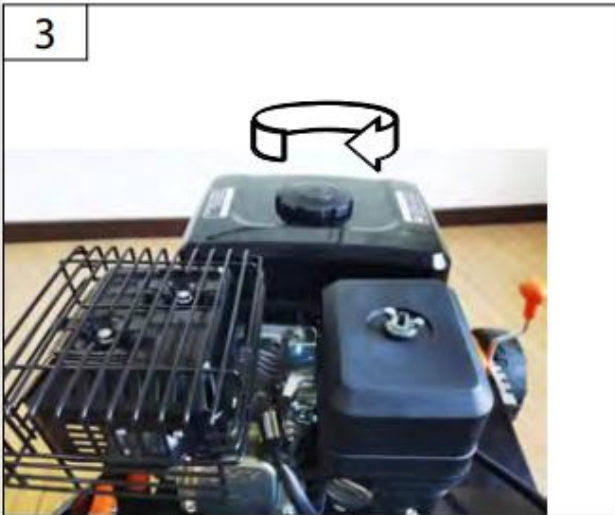
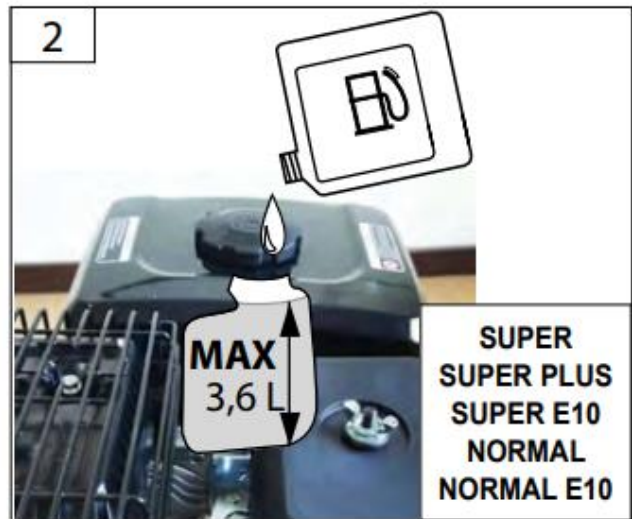
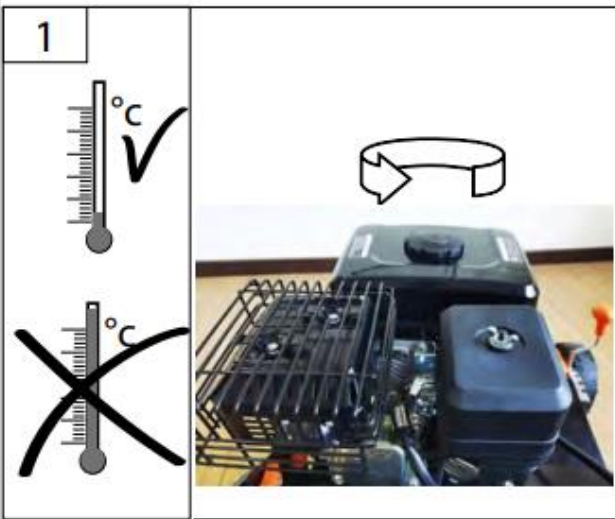

# Instrucciones de corte

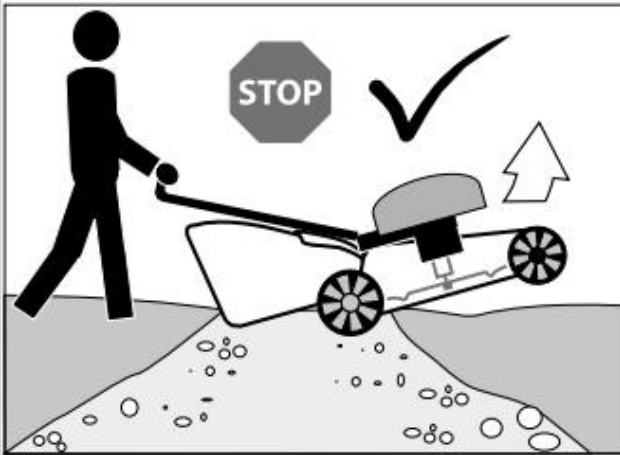
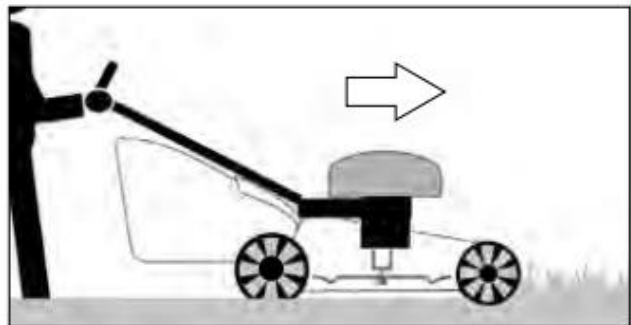
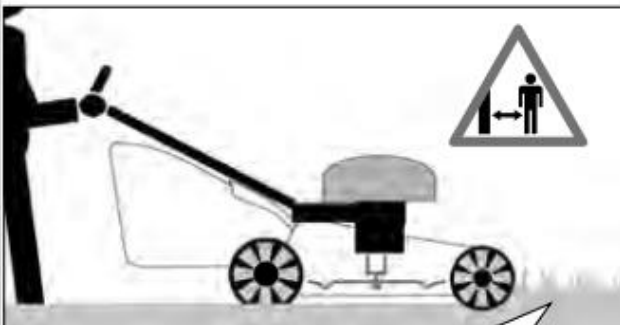

# START 4 STOP

## Operación

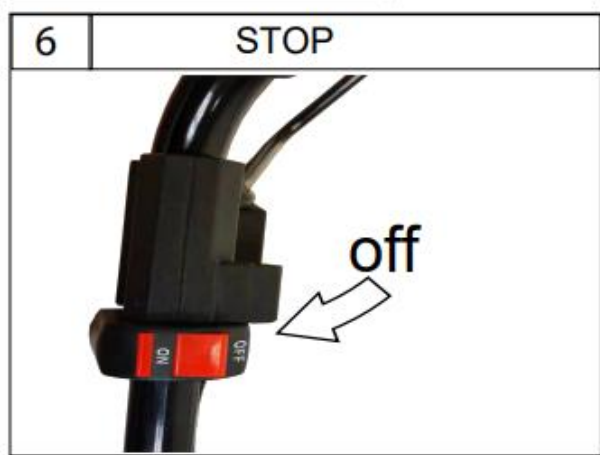
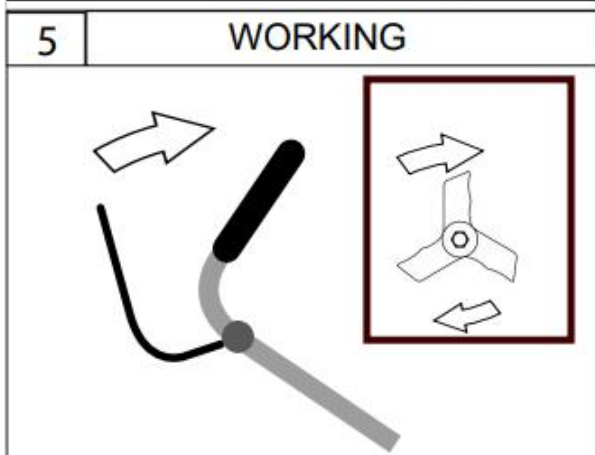
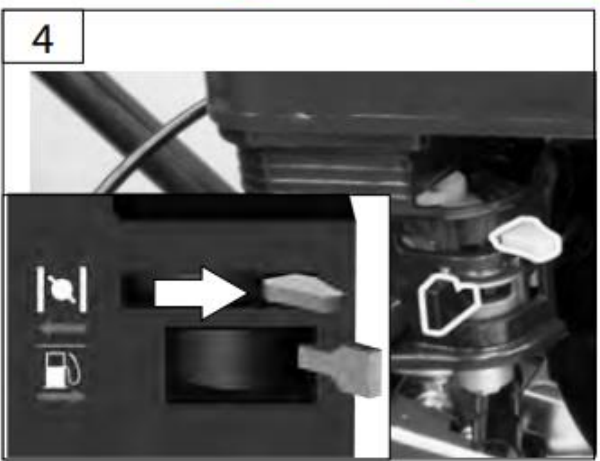
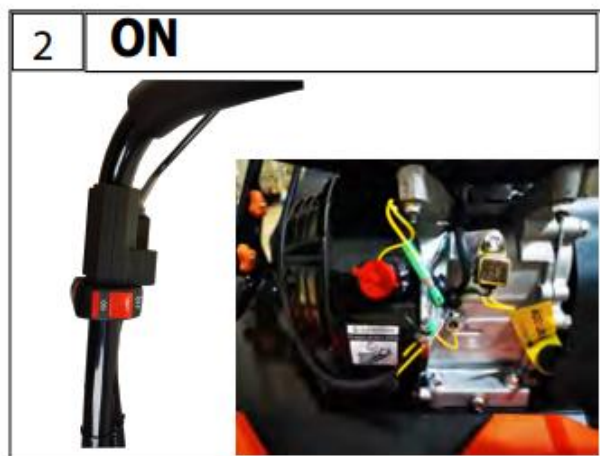
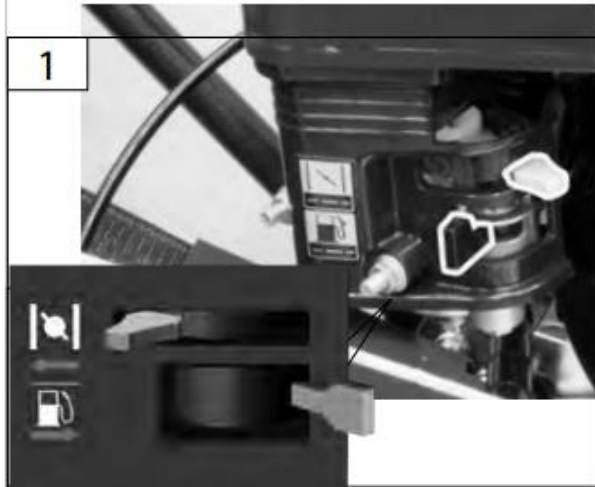

# Limpieza/mantenimiento

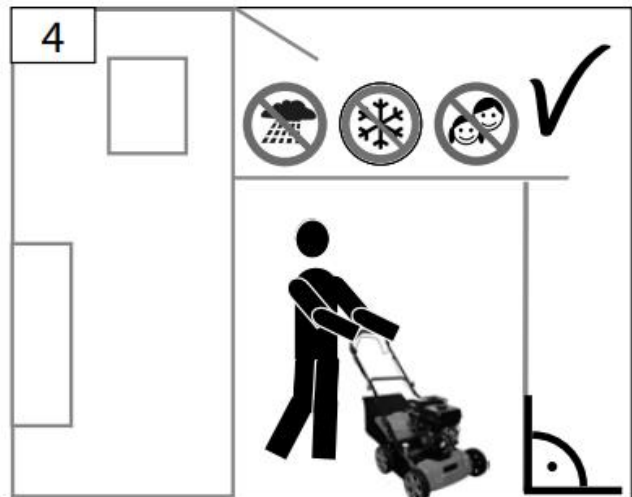
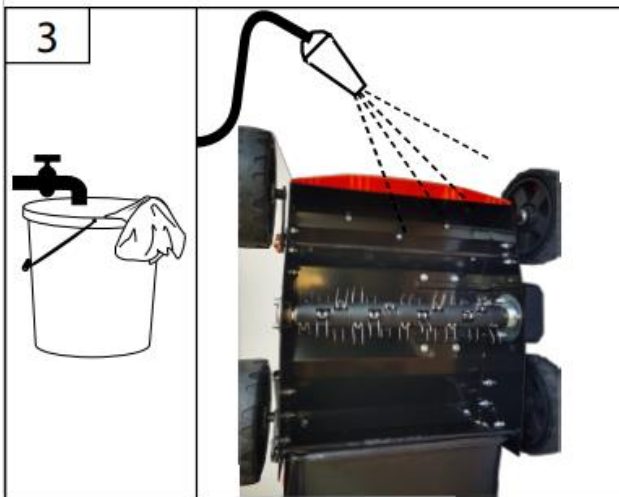
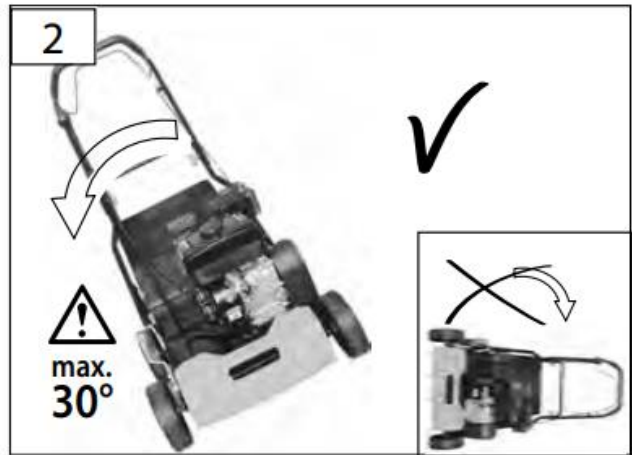

# Limpieza/mantenimiento

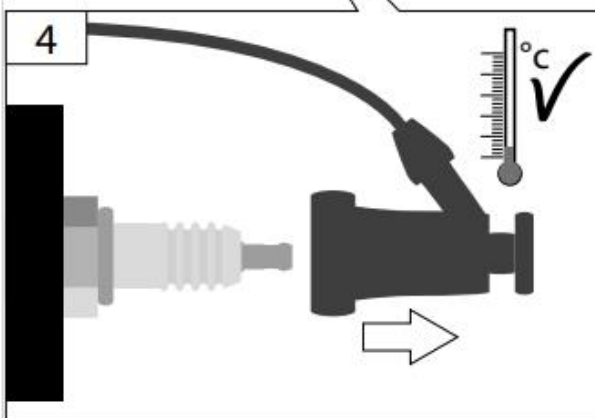
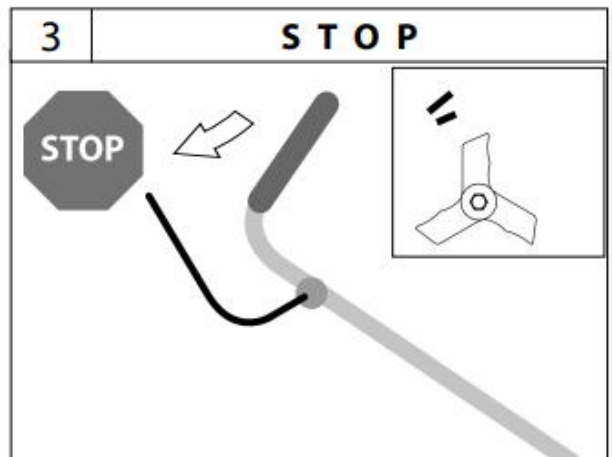
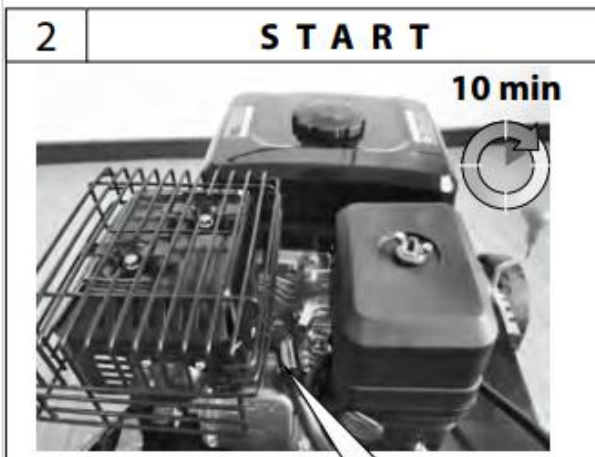
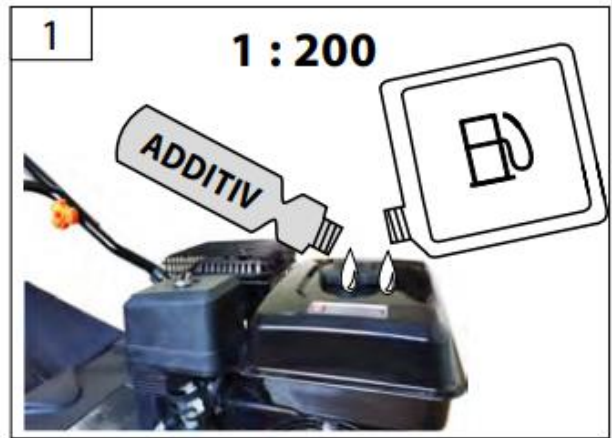
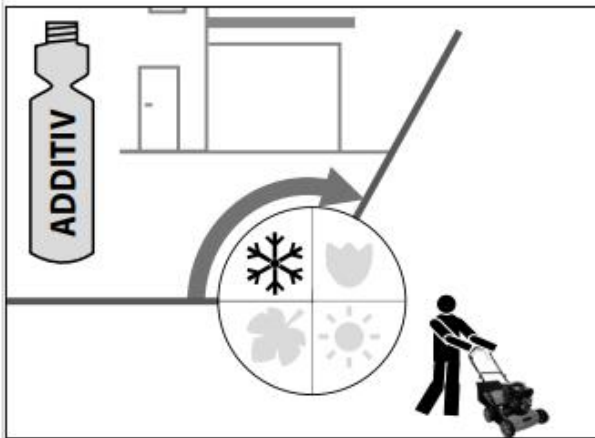

# Bujía

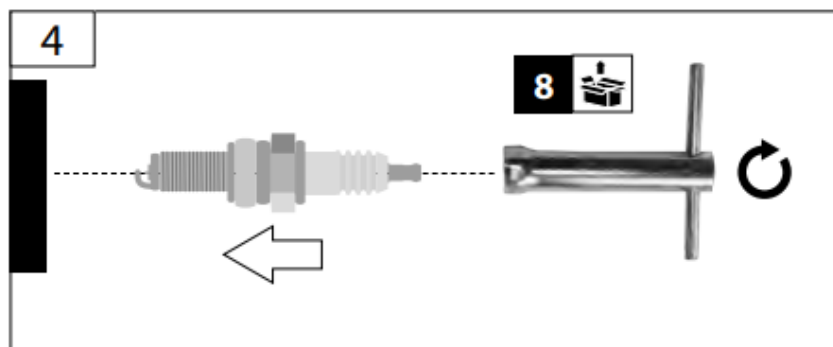
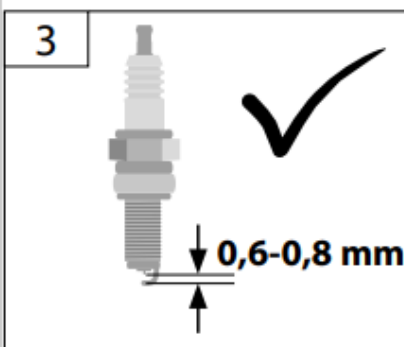
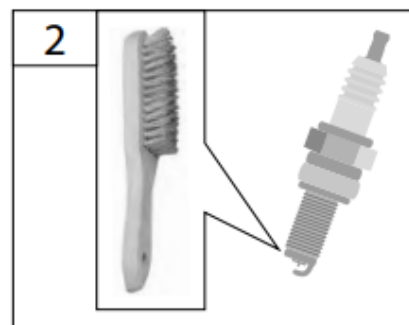
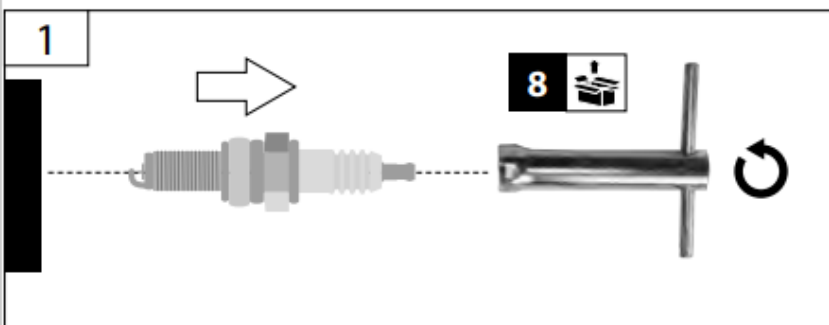
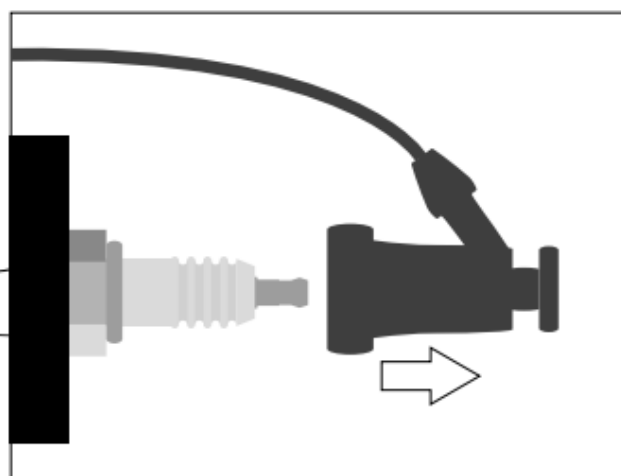
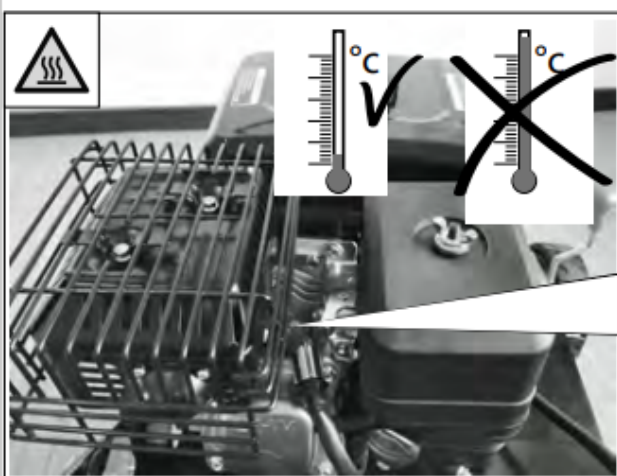

## Sustitución del aceite



6

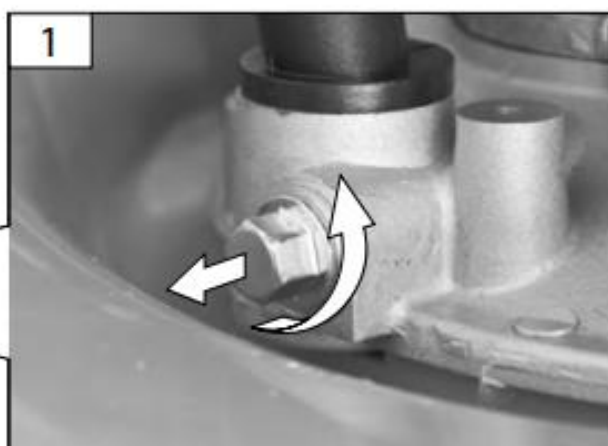

2



# Filtro de aire

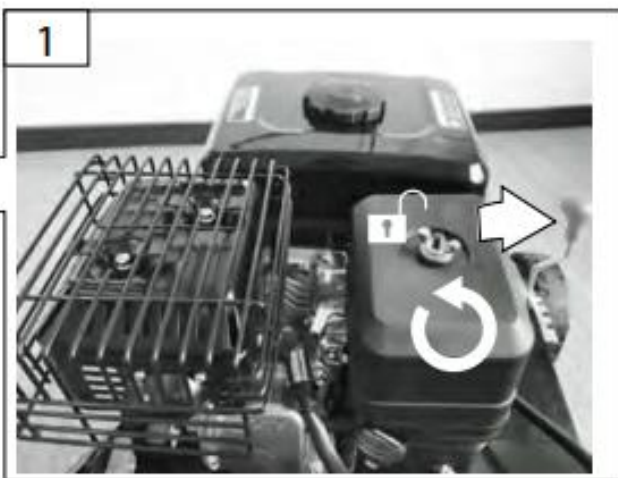



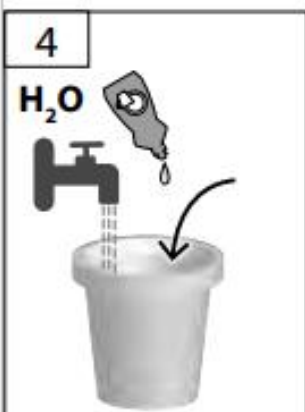





¡El filtro de papel sólo debe limpiarse con aire comprimido!  
Nunca utilice agua.





# Ficha técnica

## Escarificador de césped

Art. No	<b>PS 700-25</b>
 Cilindrada	208cm <sup>3</sup>
 Potencia motor OHV de 4 tiempos	4.3 kW (5,8 PS)
 Velocidad nominal	3600 min <sup>-1</sup>
 Ancho de corte	400 mm
 Profundidad de corte	-15 / -10 / 0 / +10 / +15 mm
 Capacidad del recogedor	50 L
 Capacidad del depósito	3,6 L
	Gasolina super/sin plomo/E10
 Peso	35 kg

### Información de ruido/vibración

 Nivel de presión sonora ponderado LpA	86,5 dB (A)
 Nivel de potencia sonora LWA	103 dB (A)

### ¡Use protección para el oído!

Valor de emisión de vibraciones  $4.34 \text{ m/s}^2$   
 $K=1,5 \text{ m/s}^2$

**ADVERTENCIA:** El nivel de emisión de vibraciones varía en función del uso que se haga de la máquina y puede aumentar en comparación con el nivel indicado en esta ficha.

El nivel de emisión de vibraciones puede utilizarse para comparar una máquina con otra. Puede utilizarse para una evaluación preliminar de la exposición.

Una estimación del nivel de exposición a las vibraciones también debe tener en cuenta los momentos en que el instrumento está apagado o cuando está en funcionamiento pero no se utiliza.

Esto puede reducir significativamente el nivel de exposición durante el período de trabajo general. Adopte medidas de seguridad adicionales para proteger al operario de los efectos de las vibraciones, como: realizar un mantenimiento periódico de la máquina y los accesorios, mantener las manos calientes, organizar los métodos de trabajo.



Lea y entienda las instrucciones de seguridad antes de operar la máquina.

Familiarícese con los componentes operativos y el uso correcto del aparato.

Respete todas las medidas de seguridad indicadas en el manual de mantenimiento.

Compórtese de manera responsable hacia los demás.

El operador es responsable por los accidentes o riesgos a terceros.

En caso de duda sobre la conexión y el funcionamiento, póngase en contacto con nuestro servicio de atención al cliente.

### Información sobre contención del ruido

Un cierto nivel de ruido generado por este dispositivo es inevitable. Realizar trabajos muy ruidosos en los horarios permitidos y especificados.

Observar los períodos de silencio exigidos por la ley y limitar la duración del trabajo al mínimo necesario.

Para protegerse a sí mismo y a su entorno, debe usar protección auditiva.

### Condiciones específicas de uso

El escarificador no debe utilizarse para otros fines, ya que puede suponer un riesgo de lesiones físicas para el usuario y otras personas.

No utilice el producto de forma distinta a la indicada para su uso normal.

El incumplimiento de la normativa general vigente y las instrucciones de este manual excluye al fabricante de cualquier responsabilidad por daños.

 **Utilice el aparato sólo al aire libre, nunca en lugares cerrados y mal ventilados.**

 **El escarificador no debe utilizarse para podar arbustos y setos, para cortar viñas o césped en tejados verdes o jardineras. Además, el escarificador no debe utilizarse como trituradora para triturar árboles y setos ni para nivelar superficies irregulares.**

### Requisitos para el personal operativo

Nunca permita que los niños utilicen el cortacésped.

No permita que los adultos trabajen con la máquina a menos que hayan recibido la formación adecuada.

Antes de utilizar el aparato, el personal debe leer atentamente el manual de instrucciones.

**Cualificaciones:** aparte de las instrucciones detalladas de un experto, no se requieren cualificaciones especiales para utilizar el dispositivo.

**Edad mínima:** Solo las personas mayores de 16 años pueden operar la máquina. La excepción son los jóvenes que reciben formación para adquirir conocimientos bajo la supervisión del director de formación profesional. Las regulaciones locales pueden determinar la edad mínima del usuario.

**Formación:** El uso del aparato solo requiere una formación adecuada por parte de un profesional o manual de usuario. No se requiere formación específica.

**Riesgos**

 **Las cuchillas giratorias pueden causar lesiones graves al cortar o amputar partes del cuerpo.**

Nunca toque debajo del cuerpo del chasis cuando el motor está funcionando. Utilice calzados de seguridad. Nunca retire el recogedor cuando la máquina está en funcionamiento.

 **Las piedras o la suciedad pueden causar lesiones si se tiran de la máquina.**

Asegúrese de que el recogedor esté suspendido correctamente.  
Use gafas de seguridad cuando trabaje.

 **Las condiciones de pobre iluminación representan un alto riesgo para la seguridad.**

Proporcionar iluminación adecuada o buenas condiciones de iluminación al operar la máquina.

**Procedimientos de emergencia**

 **¡Peligro de lesiones!**

No ponga las manos o los pies cerca o debajo de las piezas giratorias. Manténgase a una distancia prudencial de la salida.

 **¡Peligro de quemaduras!**

Algunas partes del producto se calientan durante el funcionamiento. No toque las piezas calientes. Por ejemplo, el motor y el silenciador.

Realice un procedimiento de primeros auxilios adecuado al tipo de lesión y llame a personal médico calificado lo antes posible. Proteja a la persona herida de daños mayores y tranquilícela. Para hacer frente a un accidente de acuerdo con la norma DIN13164, un lugar de trabajo debe estar equipado con un botiquín de primeros auxilios. Es esencial que el contenido del botiquín de primeros auxilios se sustituya inmediatamente después de su uso.

En caso de una solicitud de ayuda, por favor proporcione la siguiente información:

1. Lugar del accidente;
2. Tipo de accidente;
3. Número de heridos;

**Símbolos**

¡Cuidado!



Lea con cuidado estas instrucciones



¡Use protección para el oído! ¡Use protección para los ojos!



Atención: las cuchillas bajan. Espere hasta que todas las partes móviles se hayan detenido.



Cuidado - ¡Superficie caliente!  
¡Peligro de quemaduras!



¡Cuidado con los objetos lanzados!



¡Mantenga a las personas no autorizadas lejos! Observe las normas de seguridad para evitar estar en un área peligrosa.



Antes de cualquier operación en el motor, apáguelo y retire el enchufe.



Mantenga suficiente espacio libre del cuchillo de corte mientras está en funcionamiento.



Cuidado, ¡riesgo de atrapamiento!



¡Riesgo de explosión!  
Repostar el motor sólo cuando esté Apagado



¡Riesgo de envenenamiento!



Utilice la máquina solo en exteriores, nunca la use en áreas confinadas y mal ventiladas.



Prohibido fumar y utilizar llamas libres



Mantenga a los niños y a las personas no autorizadas lejos de la máquina en todo momento.



No exponga la máquina a la lluvia ni la use en condiciones húmedas



¡Use zapatos resistentes a cortes con puntera de acero y suela de seguridad!





# AGRIEURO

Fraz. Petrognano, 50/D - 06049 - Spoleto - PG- Italy  
Reg. imprese di Perugia - C.F. / P. IVA (VAT code) IT01629170547

## DECLARACIÓN DE CONFORMIDAD UE

La presente declaración de conformidad se expide bajo la exclusiva responsabilidad del fabricante:

**AGRIEURO SRL**  
**Fraz. Petrognano 50/D - 06049 Spoleto (PG) - Italia**

Producto al que hace referencia la presente declaración:

<b>PRODUCTO</b>	ESCARIFICADORES PARA CÉSPED
<b>MARCA</b>	GREENBAY
<b>MODELO/S</b>	FCP400
<b>CÓDIGO/S</b>	112731
<b>NOMBRE/S</b>	PS 700-25

El producto indicado cumple la legislación comunitaria de armonización pertinente:

- Directiva 2006/42 CE
- Directiva 2014/30 UE
- Directiva 2000/14 CE y su modificación Directiva 2005/88 CE

El producto indicado cumple las siguientes normas armonizadas:

- EN 13684:2018
- EN ISO 14982:2009
- EN 3744:1995
- ISO 11094:1991

Asimismo, confirmamos lo siguiente de acuerdo con la directiva sobre emisiones 2000/14/CE modificada por la directiva 2005/88/CE:

- El nivel de potencia acústica registrado en una máquina similar a la que es objeto de la declaración de conformidad es de: 94 dB(A).
- El nivel de potencia acústica garantizado para el equipo es de: 96 dB (A).

Firmado por y en nombre de: ALESSIA SETTIMI

En: SPOLETO

A 22/05/2025

Firma

**AGRIEURO** SRL  
FRAZ. PETROGNANO 50/D - SPOLETO (PG)  
C.F. B.P.IVA 01629170547

